

# Fibre-based Versatile Broadband Access and In-Building Networks

Ton Koonen, Maria García Larrodé, Patryk Urban, Huug de Waardt,  
Christos Tsekrekos, Jia Yang, Hejie Yang, Henrie van Boom

COBRA Institute  
dept. Electrical Engineering  
Eindhoven University of Technology  
e-mail: a.m.j.koonen@tue.nl

*IET Workshop From Access to Metro  
Broadband Europe, Antwerp, Dec. 3, 2007*



## Outline



- **BB access penetration**
- **BB access networks:**
  - reconfigurable FTTH, using WDM-TDM PON
  - reconfigurable Fixed Wireless Access, using dispersion-tolerant Radio-over-Fibre technique
- **BB in-home optical networks:**
  - high-capacity wirebound techniques, using QAM
  - service multiplexing, using MGDM
  - reconfigurable inter-room wireless pico-cell communication, using Radio-over-Fibre
- **Concluding remarks**



→ fast growing need for broadband capacity at home and in access; broadband internet traffic, packet-based

[Wim Veen - TU Delft]

amjk 3

## BB penetration ratios

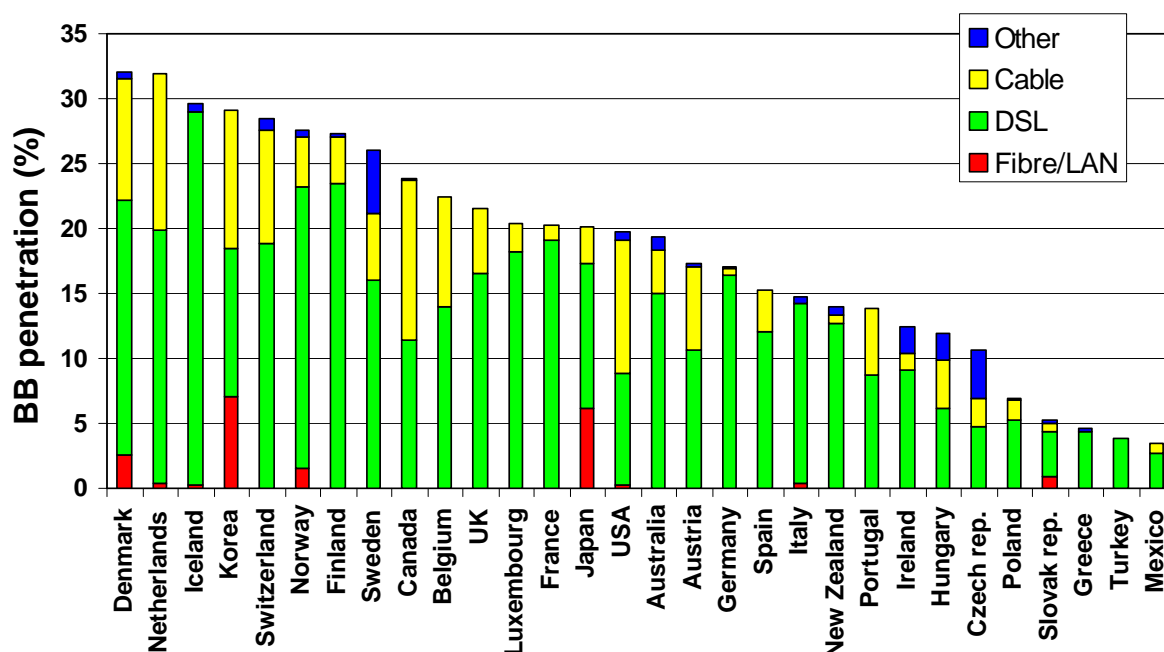

- Japan: 7.9 M FTTH connections in Dec. 2006

Source: OECD Broadband statistics, Dec. 2006

amjk 4

# BB subscriber trends in Japan

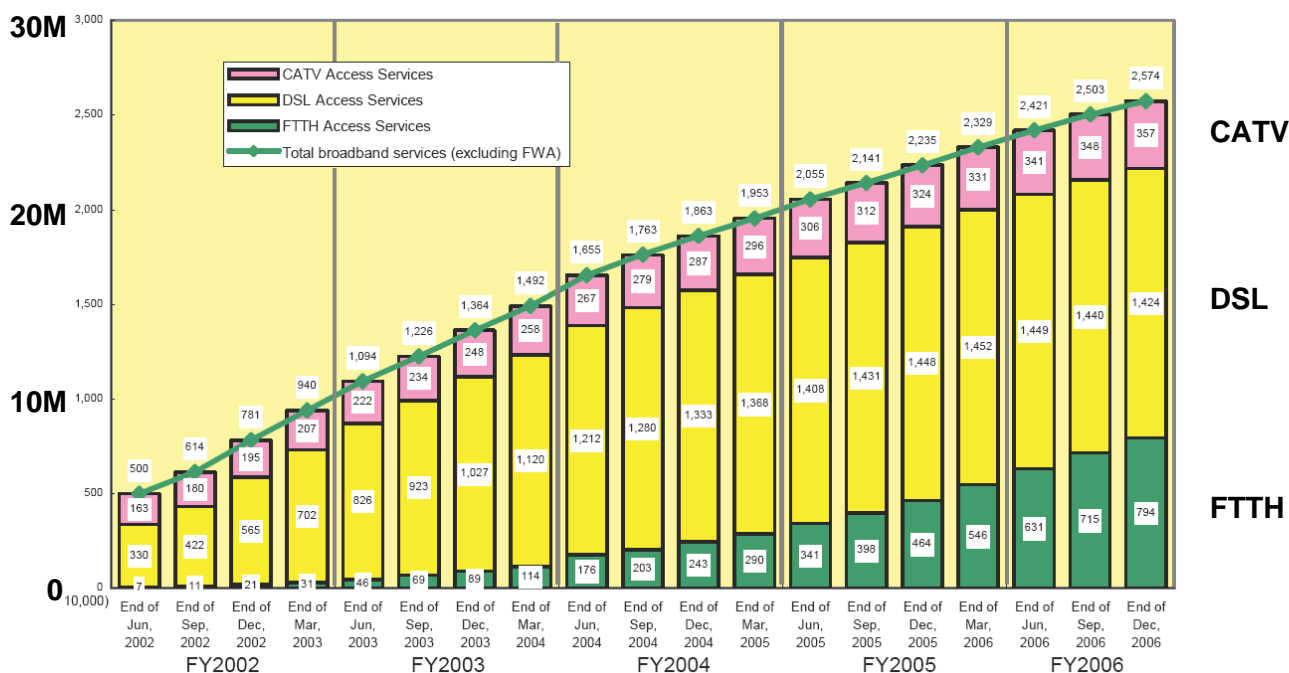

- FTTH subscribers by end 2006 (7.9 M) passed 30% of total

Source: Japan Ministry of Internal Affairs and Communications, March 13, 2007

amjk 5

# Digital divide



Distribution of major ICTs by income group of economies

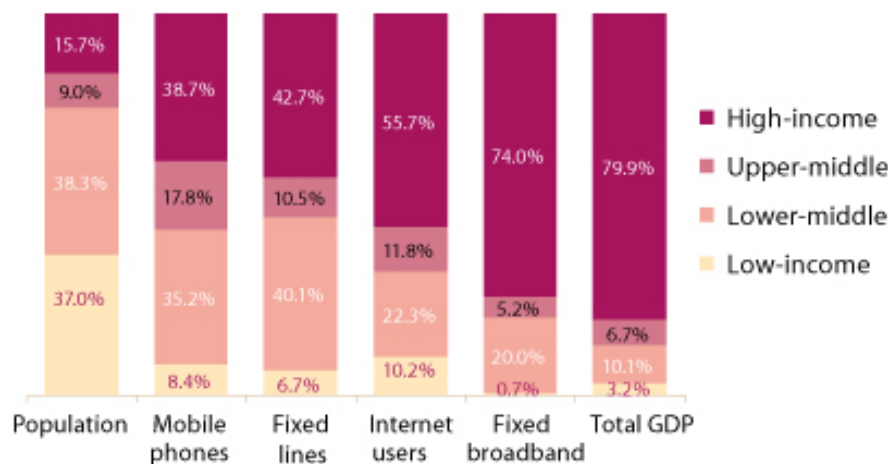

Note: Population data and ICT data are for year-end 2005, GDP data relate to year-end 2004.

- Digital divide in high-speed broadband technologies is more marked than in the other technologies: low income <1%, lower-middle 20% of global total

Source: [www.itu.int](http://www.itu.int) , ITU Corporate Strategy

amjk 6

# FTTH topologies



## P2P

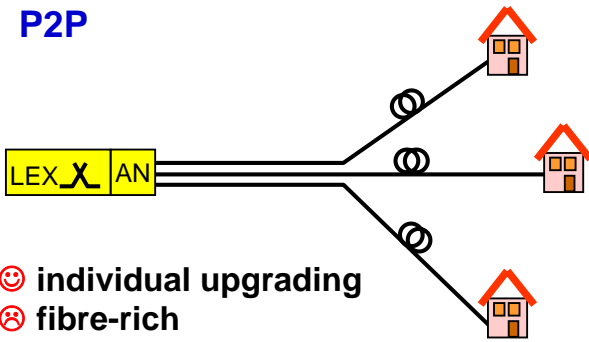

- ☺ individual upgrading
- ☹ fibre-rich

## P2MP – active star

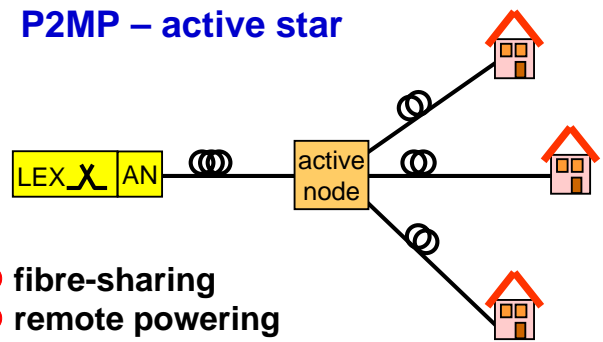

- ☺ fibre-sharing
- ☹ remote powering
- ☹ FTTC, FWA

## P2MP – passive star

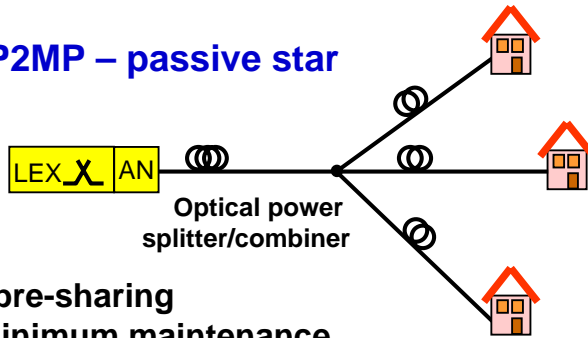

“ PON – Passive Optical Network ”

- ☺ fibre-sharing
- ☺ minimum maintenance
- ☺ lower CAPEX than P2P (for longer feeders and/or more users)

amjk 7

# Multiple access on the PON

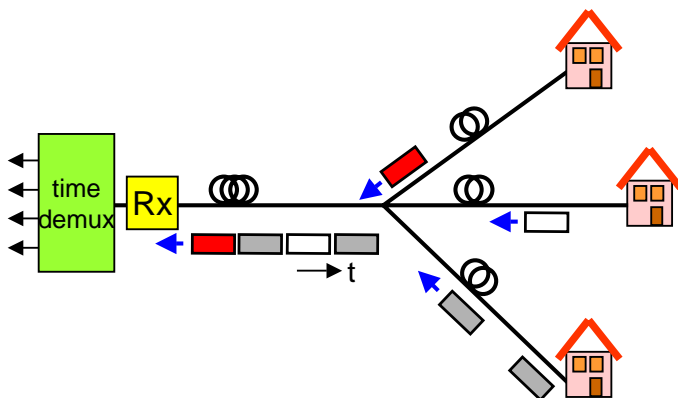

## TDM-PON

- ☺ Flexible sharing of LT capacity ⇒ efficient
- ☹ Time slot(s) per user ⇒ congestion at high loads

## WDM-PON

- ☺ each user own  $\lambda$ -channel ⇒ no congestion
- ☺ Virtual P2P
- ☹ No sharing of capacity ⇒ inefficient

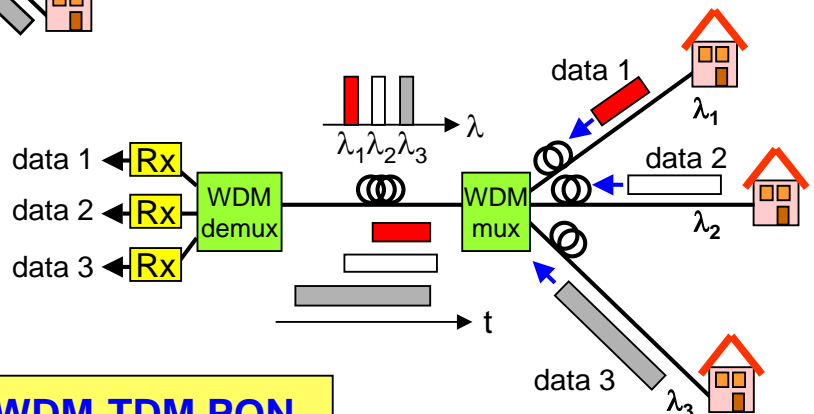

⇒ Combine into hybrid WDM-TDM PON

amjk 8

# Dynamic wavelength routing in access networks

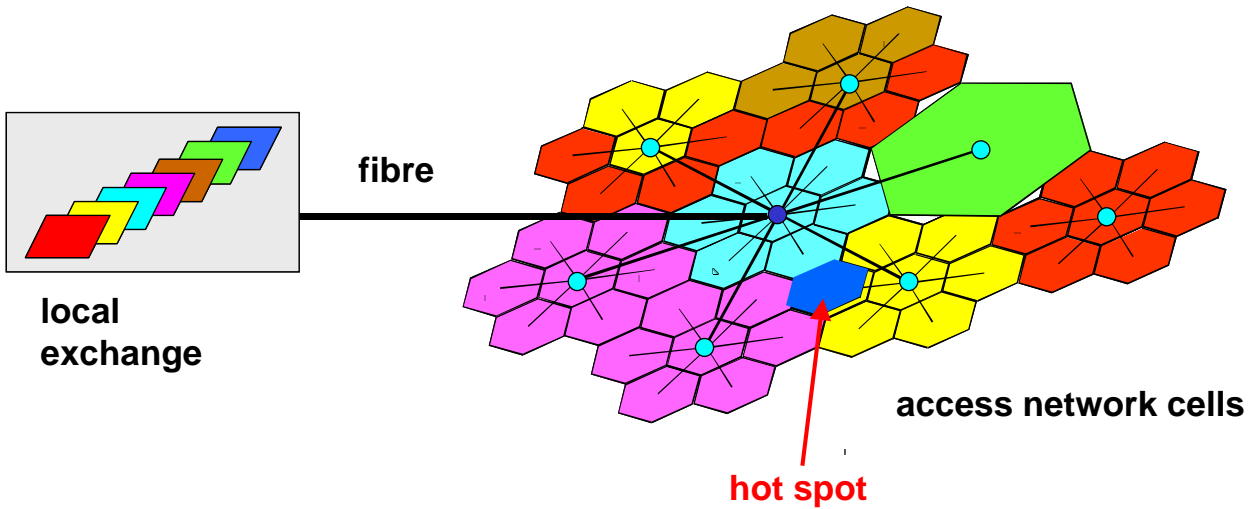

- e.g. for hybrid WDM-TDM PON (large scale, long reach)
- to provide capacity-on-demand
- optimises utilisation of network resources

amjk 9

# Wavelength-agile FTTH

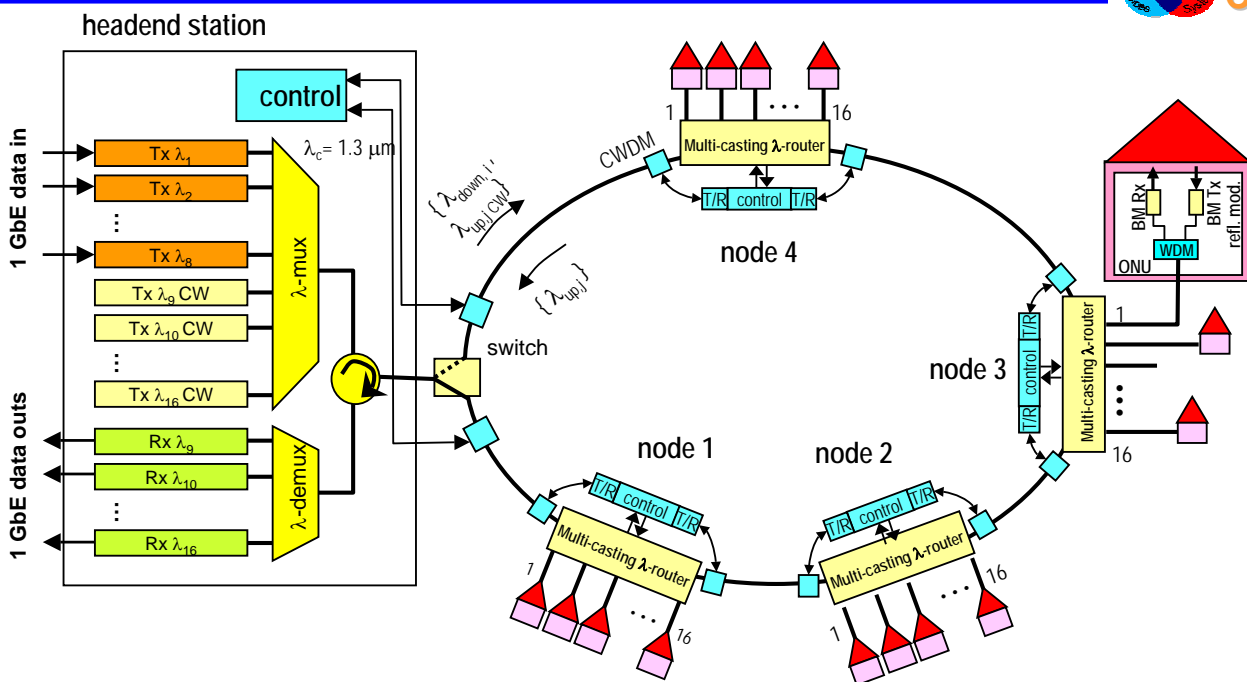

- flexibly allocating one or more  $\lambda$ -s per home, using ROADMs
- incl. protection
- colourless ONUs

amjk 10

# Multi-casting $\lambda$ -add/drop/continue

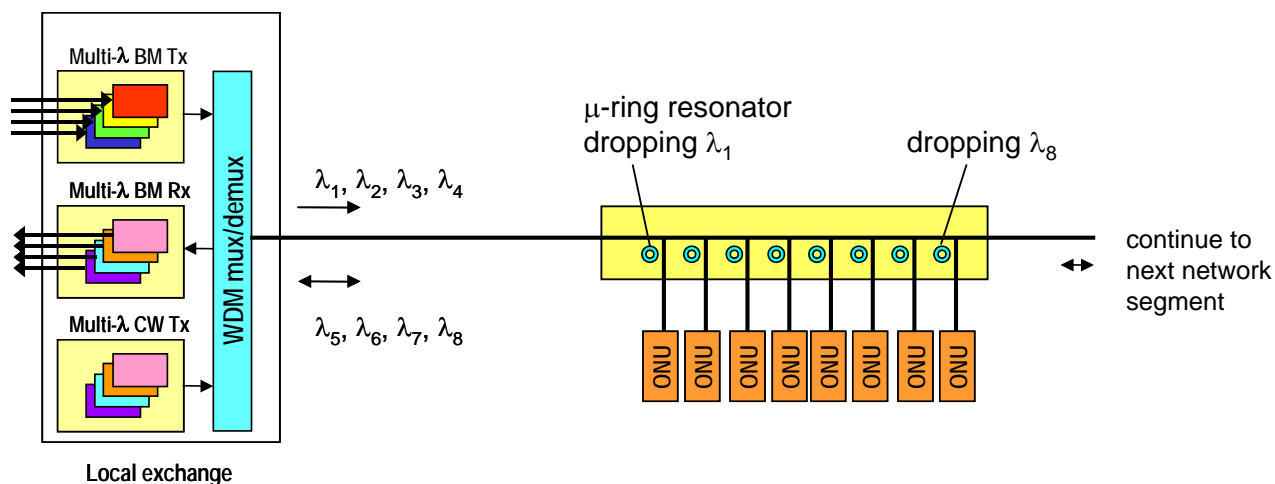

- thermally tunable micro-ring resonators
- 1x4 matrix

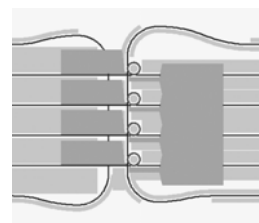
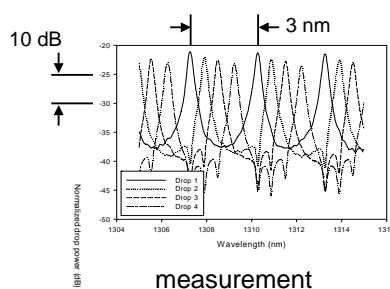

1x4 add/drop



amjk 11

# Integrated reflective transceiver

- colourless ONU, using a reflective SOA
- optical functions in quantum-dot InP IC, electronics in silicon 10 Gbit/s
- with bulk devices, >1.25 Gbit/s achieved

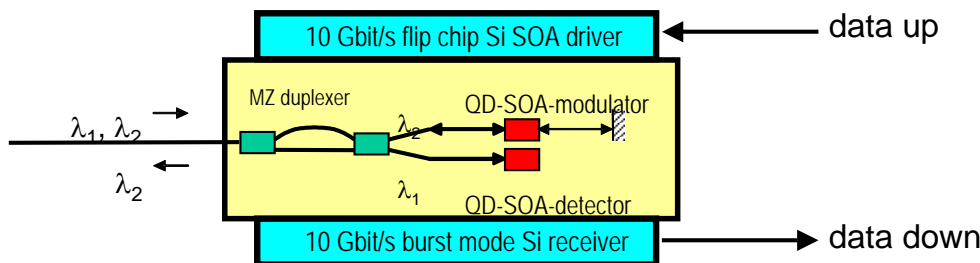

### SOA modulator:

- Modulating rate up to 1Gbit/s
- Fibre-fibre gain up to 9 dB at 90 mA injection current

### Photodetector:

- Responsivity up to 0.4 A/W at -2V
- Bandwidth up to 25 GHz



amjk 12

# Radio over Fibre

increase capacity  $\rightarrow$   
big cells have to  
shrink

To increase capacity:  
Smaller cells  $\rightarrow$  more antenna sites  
Higher frequencies  $\rightarrow$  more complexity

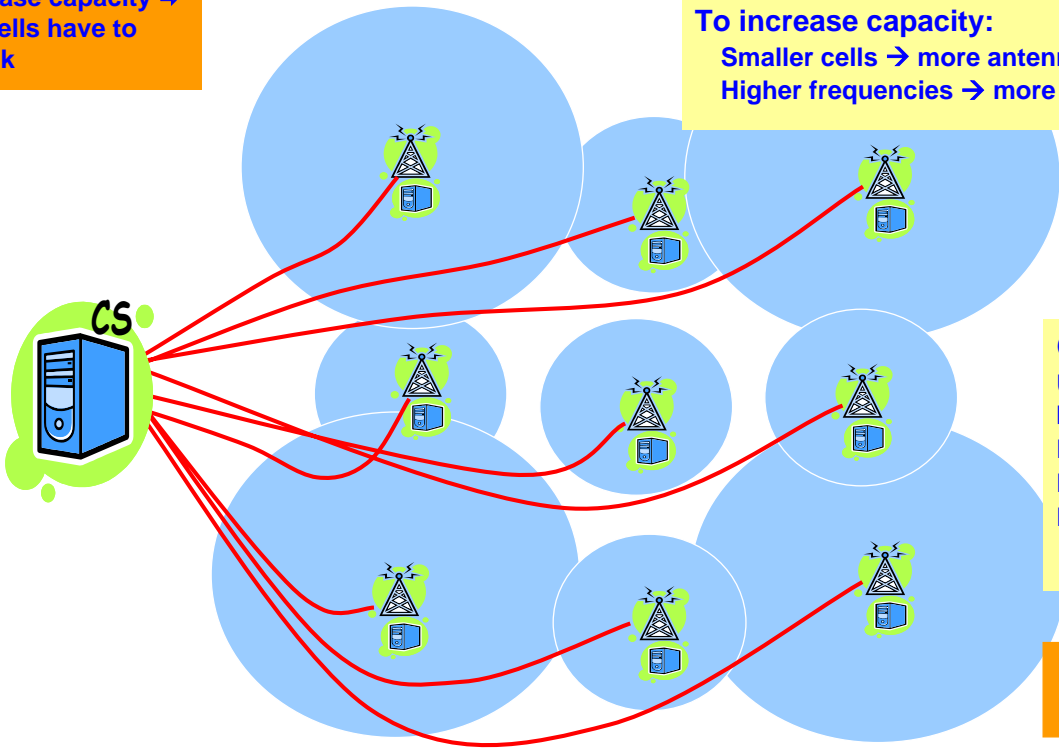

**Optical Fibre**  
Unlimited  
bandwidth  
Low loss  
Light weight  
EM immunity

**Radio over Fibre**

amjk 13

# Generating microwaves by Optical Frequency Multiplying

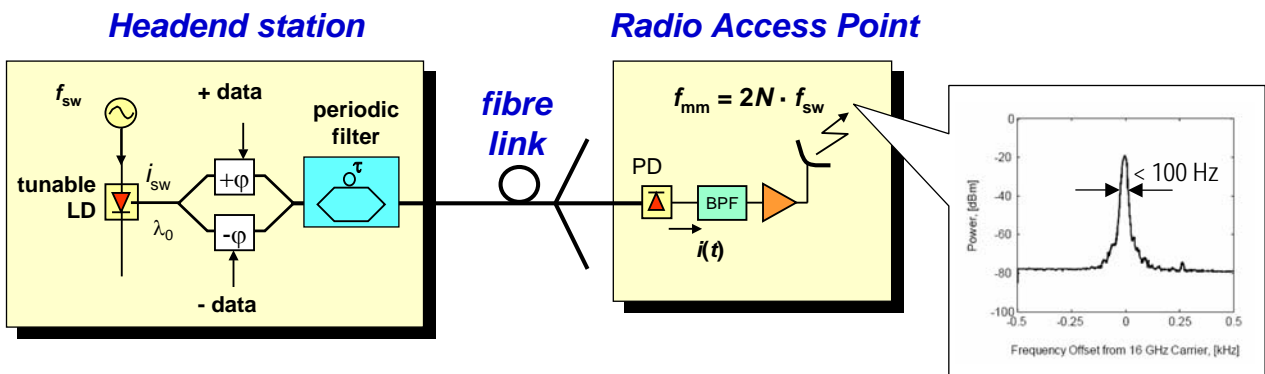

- generating harmonics of laser sweep frequency by FM-to-IM conversion in periodic filter
- simple antenna station
- very pure microwave  $\rightarrow$  high wireless capacity
- dispersion-tolerant  $\rightarrow$  for SMF, and MMF

amjk 14

# Dynamic capacity allocation in FWA

- Multi-standard operation
- RAP is  $\lambda$ -agnostic, may handle multiple RF signals
- Link switching requires dispersion-robust RoF

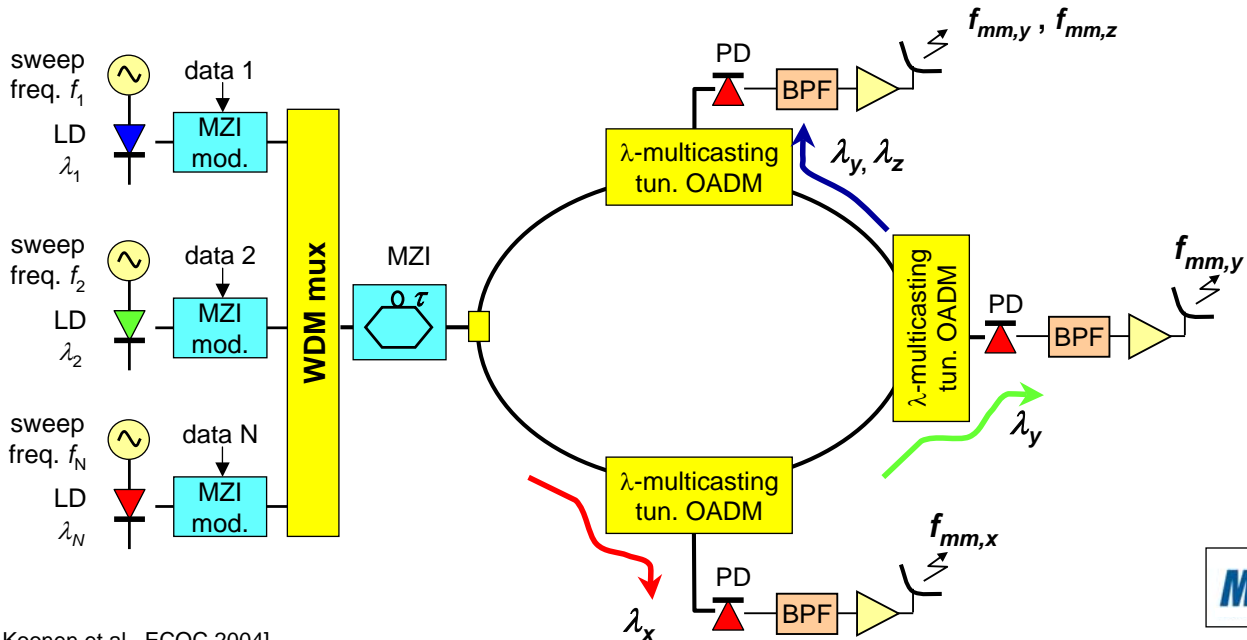

[T. Koonen et al., ECOC 2004]



amijk 15

# 64-QAM experiment over silica GI-MMF

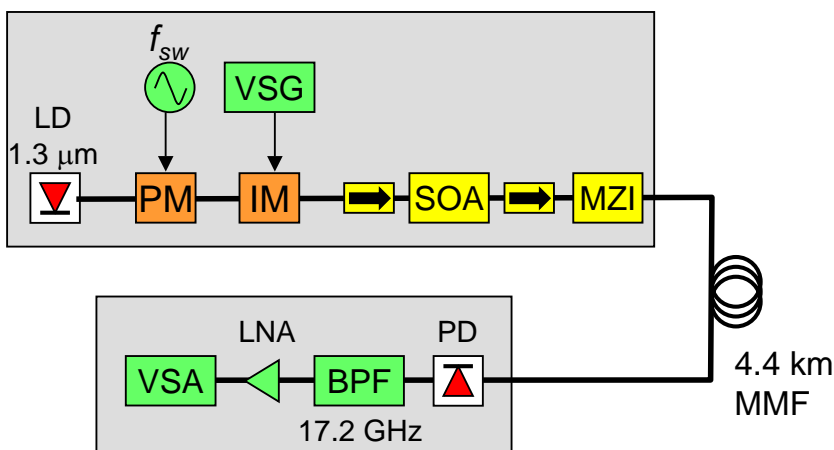

- $\mu$ -wave carrier freq. 17.2 GHz
- 64-QAM on subcarrier freq. 127 MHz
- symbol rate 20 MBaud  $\rightarrow$  120 Mbit/s
- 4.4 km silica  $\varnothing$ 50  $\mu$ m core GI-MMF
- also with 25 km SMF @ 39.9 GHz
- multi-tone (up to 10 tones) 64-QAM operation at 18.3 GHz over the GI-MMF link shown

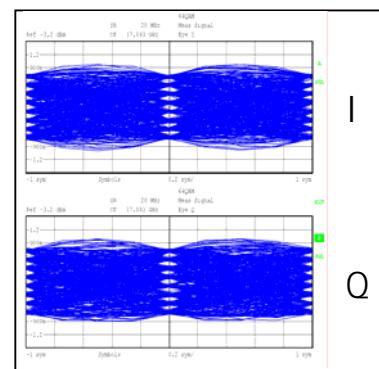
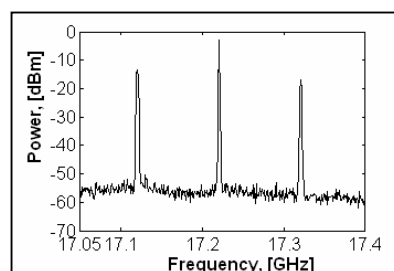

EVM = 4.8 % (< 5.6 % req.)



[A. Ng'oma et al., OFC2005]  
[M. Garcia Larrode et al., EL 2006]

amijk 16

# Impact of SMF chromatic dispersion

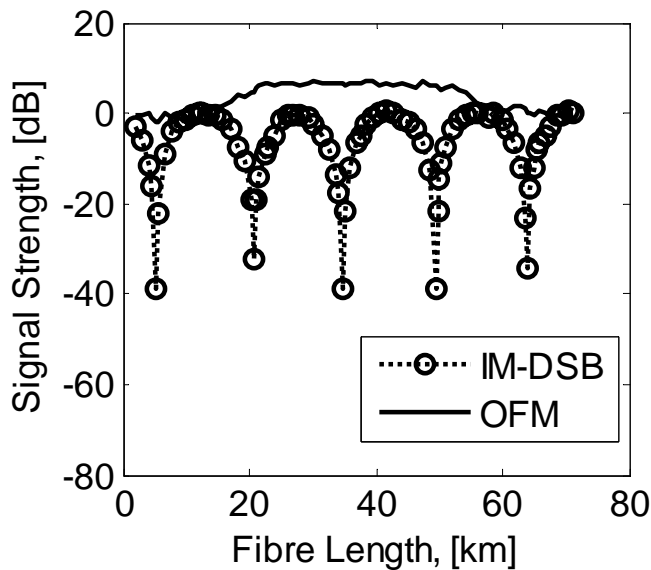

Measured\* delivered normalised strength of 22 GHz carrier at  $\lambda=1.55 \mu\text{m}$ , using

- Intensity-modulation, double sideband (IM-DSB)
- Optical Frequency Multiplying (OFM; 5<sup>th</sup> harmonic)

⇒ **OFM is tolerant against chromatic fibre dispersion, and hence suitable for link-switched routing.**

\* excluding fibre losses



[A. Ng'oma et al., Int. Microwave Symp. 2007]  
[T. Koonen et al., OECC 2006]

# Versatile BB in-home networks

**Converged in-home backbone network, integrating wired & wireless services**

- reduces installation and maintenance efforts
- eases introduction and upgrading of services

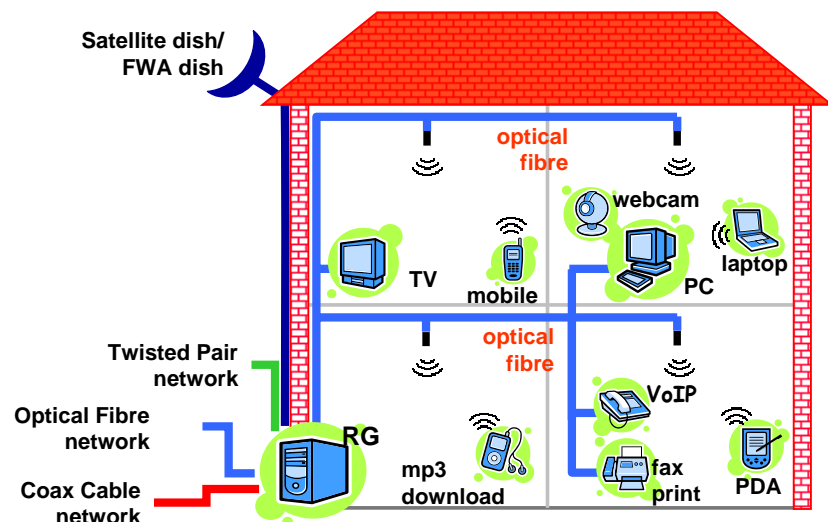

coax

POF

SMF

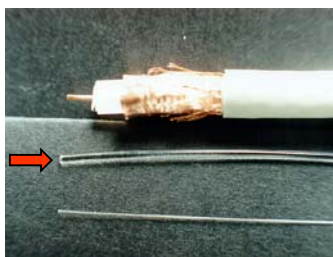

→ converged in-home network on POF

# Direct-QAM 1 Gbit/s over 1 mm core SI-POF

## Experimental setup

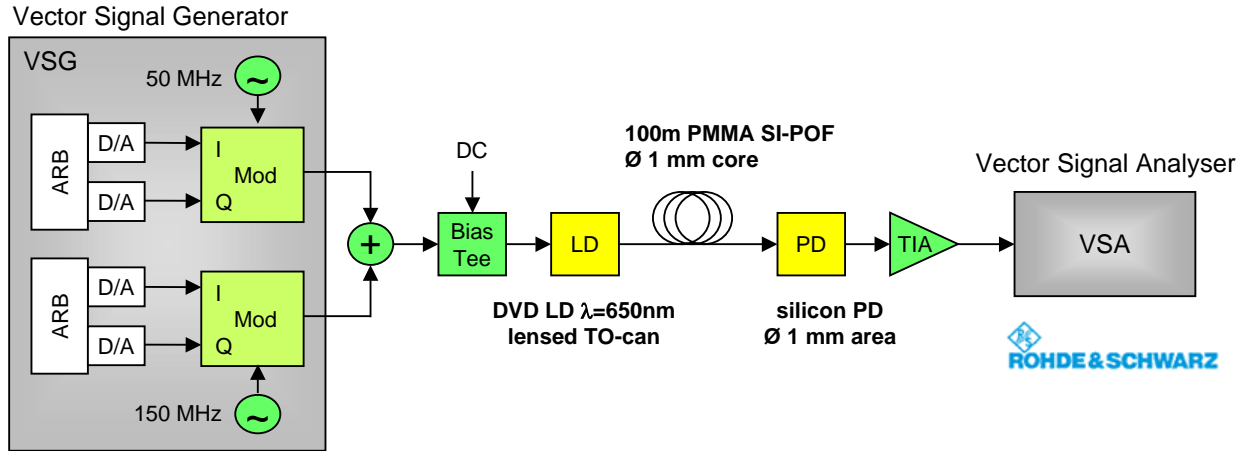

- 2 Channel VSG, with 2 x 40 sub-carriers, 2 MHz spaced, 1.8 MBaud at QAM-64 and -256

## WDM-emulated QAM-64

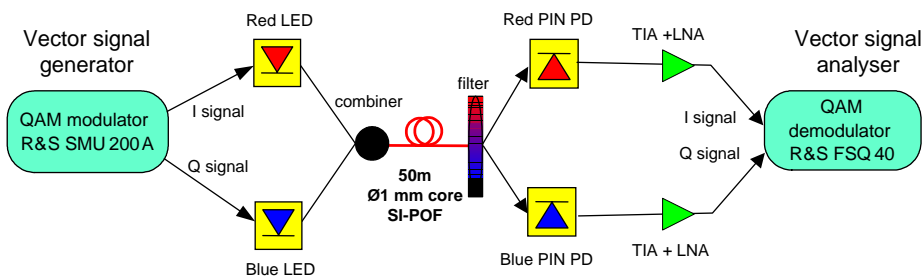

CF=0  
QAM-64  
15 MS/s  
(so 90 Mbit/s)

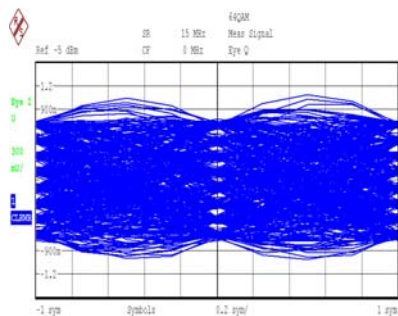

Blue WDM 50 m

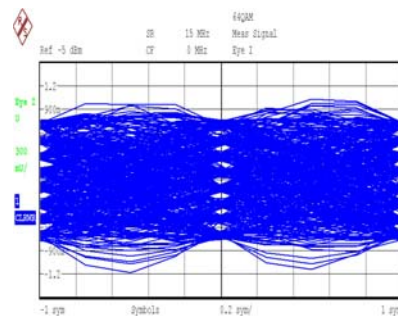

Red WDM 50 m

Still needed:

- Linearisation of LEDs
- Phase alignment of I and Q channels, in order to get a good QAM signal constellation for demodulation

# Mode Group Diversity multiplexing

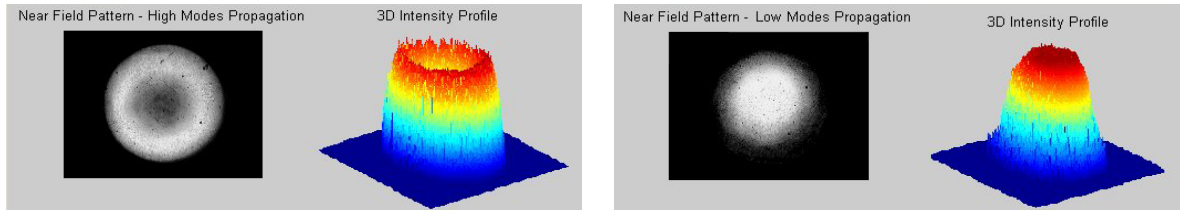
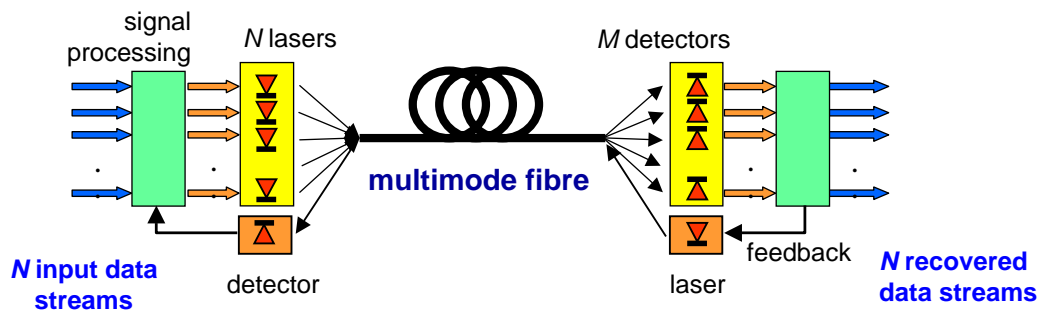

high-order modes

low-order modes

- selective mode group launching
- *issue*: mode mixing
- MIMO-like processing
- for service multiplexing

[Koonen et al., OFC 2004]

amjk 21



# Video/Audio transmission

- Basic demo: 2 channels MGDM (video + audio)

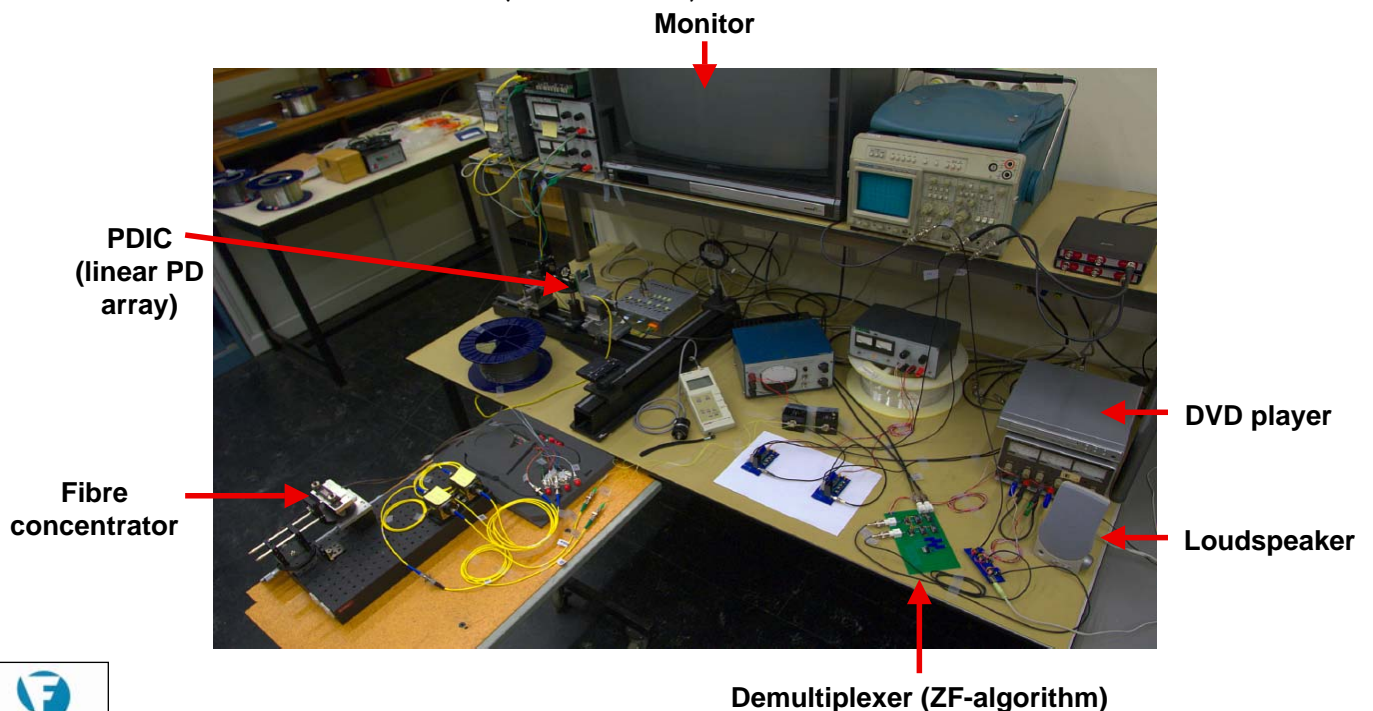

amjk 22

# Bi-dir. radio-over-MMF using OFM

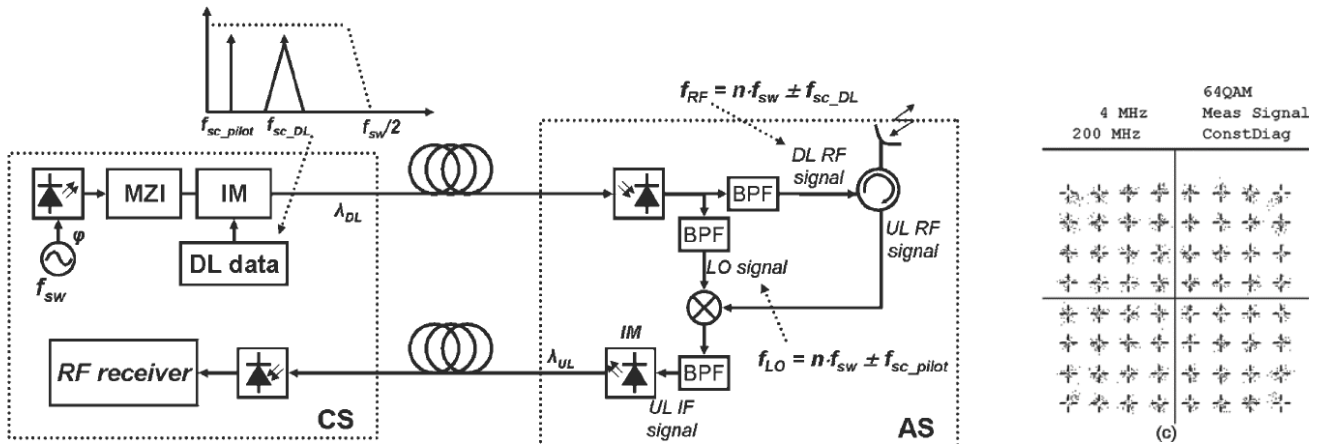

- 4.4 km Ø50 µm core GI-MMF
- downlink 24 Mbit/s QAM-64 at 17.7 GHz
- uplink 24 Mbit/s QAM-64 at 5.8 GHz
- subcarrier freq. 200 MHz
- also 100 Mbit/s QAM-16 over 100m Ø50 µm core GI-POF

I-Q constellation recovered at CS  
EVM=5.8%



[M. Garcia Larrode, PTL 2006]

amjk 23

# Inter-room µ-wave wireless communication

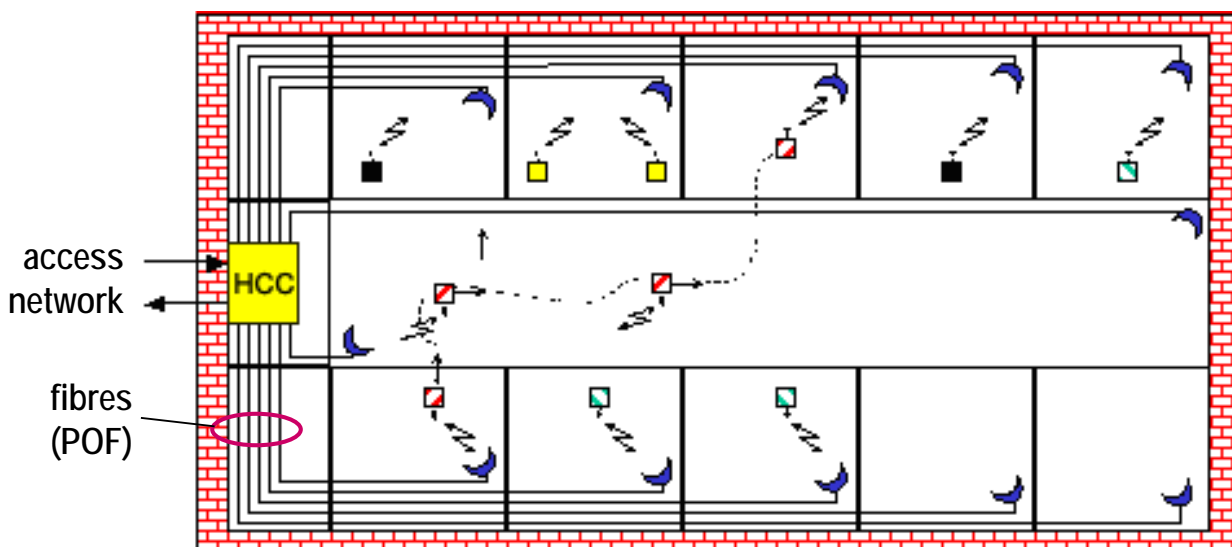

HCC: Home Communication Controller

- transparent for any wireless signal format
- any-to-any room communication
- multi-casting



amjk 24

## Concluding remarks



- Optical fibre techniques enable future-proof, versatile and high-capacity service provisioning in access and in-home networks.
- In Access networks,
  - *hybrid WDM-TDM PON* offers good scalability, upgradability and efficiency
  - in addition, *flexible wavelength routing* provides capacity-on-demand and thus optimises efficiency of the system's resources.
- In In-Home networks,
  - *multimode (polymer or silica) optical fibre* enables (DIY) low-cost integration of services, both fixed and wireless
  - and alternative service multiplexing with *Mode Group Diversity Multiplexing*
  - *comprehensive modulation formats*, i.c. QAM, enable high data rates on highly dispersive POF links.
- Radio-over-fibre combines the strengths of wirebound and wireless communication, both in Access and in In-Home networks, in particular when applying flexible wavelength routing using the dispersion-robust *Optical Frequency Multiplying* technique.

amjk 25

## Acknowledgement



### Funding from

- the European Commission
    - in the FP6 project *MUSE – Multi-Service Access Everywhere*,
    - in the FP6 project *POF-ALL*,
    - in the FP6 Network of Excellence *e-Photon/ONe +*, and
    - in the FP6 Network of Excellence *ISIS*
  - the Dutch Ministry of Economic Affairs
    - in the *IOP Generieke Communicatie* programme, and
    - in the *Freeband* programme
- is gratefully acknowledged.



amjk 26