



DTF2.1 – First approved version of ETSI Spectral Management, part 2 (TR 101 830-2), technical methods for performance evaluations

Author:

Rob F.M. van den Brink
TNO Telecom
PO Box 5050, 2600 GB Delft, The Netherlands
R.F.M.vandenBrink@telecom.tno.nl

Rapporteur + Editor Spectral Management for ETSI-TM6

Identifier: Deliverable D TF2.1, approved by ETSI
Class: Report
Version: V03
Version Date: 30-sept-2005
Distribution: Public
Responsible Partner: TNO

Filename: MUSE_DTF2.1 _SpectralManagement2_V03.doc

DOCUMENT INFORMATION

<i>Project ref. No.</i>	IST-6thFP-507295
<i>Project acronym</i>	MUSE
<i>Project full title</i>	Multi-Service Access Everywhere
<i>Security (distribution level)</i>	Public
<i>Contractual delivery date</i>	Dec 2004
<i>Actual delivery date</i>	16-nov-2004 (version V01) – working group approved 1 st time 8 sept 2005 (version V02) – working group approved 2 nd time 30 sept 2005 (version V03) – fully approved by ETSI
<i>Deliverable number</i>	DTF2.1
<i>Deliverable name</i>	First version of the “ETSI SpM-2” standard (Spectral Management, part 2)
<i>Type</i>	Report
<i>Status & version</i>	Officially approved by ETSI , and will be published soon by ETSI as TR 101 830-2
<i>Number of pages</i>	65+3
<i>WP / TF contributing</i>	TF2 (<i>mainly directly through ETSI-TM6 channels</i>)
<i>WP / TF responsible</i>	Les Humphrey
<i>Main contributors</i>	TNO, EAB, IFX, DT, TS, ALC
<i>Editor(s)</i>	Rob van den Brink – TNO Telecom – Rapporteur/Editor for ETSI Spectral Management
<i>EU Project Officer</i>	Pertti Jauhiainen
<i>Keywords</i>	Spectral Management, unbundling, access network, local loop, copper, twisted pair, transmission, crosstalk, modem, xDSL, ISDN, ADSL, SDSL, HDSL, VDSL.
<i>Abstract (for dissemination)</i>	This document gives guidance on a common methodology for estimating the impact of noise on xDSL performance. It provides the reader with computing models of transmitters, receivers, cable loss and crosstalk coupling for a variety of Spectral Management studies. The document is a consolidated Technical Report, approved by ETSI, and will be soon be published by ETSI as TR 101 830-2

DOCUMENT HISTORY

Version	Date	Comments and actions	Status
V01	16-11-2004	ETSI-TM6 draft version (m01p20a9), after resolving all editorial comments from the official ETSI AbC voting procedure, but after leaving all the other comments “for further study”.	Delivered by MUSE, and draft for ETSI-TM6.
V02	08-09-2005	ETSI-TM6 draft version (m01p20a13) that achieved for the second time the status of “working group approved”. This version is currently under AbC, which is an official voting procedure from ETSI that is out of control of MUSE	Upgraded (tripled in size) and delivered by MUSE, to ETSI.
V03	30-09-2005	ETSI-TM6 draft version (m01p20a15) has successfully passed the approval procedure from ETSI, and will be published soon by ETSI as TR 101 830-2	Editorial changes only, and has in this format passed the ETSI approval process.

The text hereafter follows the layout rules as used within ETSI-TM6 to show the progress on the latest draft, forwarded to the ETSI secretariat for publication

draft ETSI TR 101 830-2 V1.1.1 (2005-09)

Technical Report

Transmission and Multiplexing (TM); Access networks; Spectral management on metallic access networks; Part 2: Technical methods for performance evaluations;

This version contains the editorial corrections, that have been captured so far by the ETSI secretariat, as well as what has been agreed during the September meeting of ETSI-TM6, and what was received afterwards during the AbC procedure.

This is the version that is officially approved by ETSI, and has been forwarded to tmsupport@etsi.org, to prepare for official publication

Work Item Reference	DTS/TM-06030
Permanent Document	TM6(01)20
Filename	m01p20a15.pdf
Date	Sept 22 nd , 2005

Rapporteur/Editor (on behalf of KPN)	Rob F.M. van den Brink TNO Telecom PO-Box 5050 2600 GB Delft The Netherlands
---	---

tel:	+31.15.2857059
fax:	+31.15.2857349
email:	R.F.M.vandenBrink@telecom.tno.nl

**Transmission and Multiplexing (TM);
Access networks;
Spectral management on metallic access networks;
Part 2: Technical methods for performance evaluations**



Reference

DTR/TM-06030

Keywords

spectral management, unbundling, access network, local loop, transmission, modem, POTS, ISDN, ADSL, HDSL, SDSL, VDSL, xDSL

ETSI

650 Route des Lucioles
F-06921 Sophia Antipolis Cedex - FRANCE

Tel.: +33 4 92 94 42 00 Fax: +33 4 93 65 47 16

Siret N° 348 623 562 00017 - NAF 742 C
Association à but non lucratif enregistrée à la
Sous-Préfecture de Grasse (06) N° 7803/88

Important notice

Individual copies of the present document can be downloaded from:

<http://www.etsi.org>

The present document may be made available in more than one electronic version or in print. In any case of existing or perceived difference in contents between such versions, the reference version is the Portable Document Format (PDF). In case of dispute, the reference shall be the printing on ETSI printers of the PDF version kept on a specific network drive within ETSI Secretariat.

Users of the present document should be aware that the document may be subject to revision or change of status. Information on the current status of this and other ETSI documents is available at

<http://portal.etsi.org/tb/status/status.asp>

If you find errors in the present document, please send your comment to one of the following services:

http://portal.etsi.org/chaicor/ETSI_support.asp

Copyright Notification

Reproduction is only permitted for the purpose of standardization work undertaken within ETSI.
The copyright and the foregoing restrictions extend to reproduction in all media.

© European Telecommunications Standards Institute 2005.
All rights reserved.

DECT[™], **PLUGTESTS**[™] and **UMTS**[™] are Trade Marks of ETSI registered for the benefit of its Members.
TIPHON[™] and the **TIPHON logo** are Trade Marks currently being registered by ETSI for the benefit of its Members.
3GPP[™] is a Trade Mark of ETSI registered for the benefit of its Members and of the 3GPP Organizational Partners.

Contents

Intellectual Property Rights	5
Foreword	5
1 Scope	6
2 References	6
3 Definitions and abbreviations	7
3.1 Definitions	7
3.2 Abbreviations	9
4 Transmitter signal models for xDSL	10
4.1 Generic transmitter signal model	10
4.2 Transmitter signal model for "ISDN.2B1Q"	11
4.3 Transmitter signal model for "ISDN.2B1Q/filtered"	12
4.4 Line-shared signal model for "ISDN.2B1Q"	12
4.5 Transmitter signal model for "ISDN.MMS43"	13
4.6 Transmitter signal model for "ISDN.MMS43/filtered"	14
4.7 Line-shared signal model for "ISDN.MMS43"	15
4.8 Transmitter signal model for "HDSL.2B1Q"	15
4.9 Transmitter signal model for "HDSL.CAP"	17
4.10 Transmitter signal model for "SDSL"	17
4.11 Transmitter signal model for "EC ADSL over POTS"	18
4.12 Transmitter signal model for "FDD ADSL over POTS"	19
4.13 Transmitter signal model for "EC ADSL over ISDN"	20
4.14 Transmitter signal model for "FDD ADSL over ISDN"	21
4.15 Transmitter signal model for "ADSL2/J" (All Digital Mode, FDD, annex J)	22
4.16 Transmitter signal model for "ADSL2/M" (over POTS, FDD, annex M)	23
4.17 Transmitter signal model for "VDSL"	24
4.17.1 Templates compliant with the ETSI main band plan	26
4.17.2 Templates compliant with the ETSI optional band plan	29
5 Generic receiver performance models for xDSL	31
5.1 Generic input models for effective SNR	33
5.1.1 First order input model	33
5.2 Generic detection models	35
5.2.1 Generic Shifted Shannon detection model	35
5.2.2 Generic PAM detection model	36
5.2.3 Generic CAP/QAM detection model	37
5.2.4 Generic DMT detection model	38
5.3 Generic models for echo coupling	41
5.3.1 Linear echo coupling model	41
6 Specific receiver performance models for xDSL	42
6.1 Receiver performance model for "HDSL.2B1Q"	42
6.2 Receiver performance model for "HDSL.CAP"	42
6.3 Receiver performance model for "SDSL"	43
6.4 Receiver performance model for "EC ADSL over POTS"	44
6.5 Receiver performance model for "FDD ADSL over POTS"	45
6.6 Receiver performance model for "EC ADSL over ISDN"	47
6.7 Receiver performance model for "FDD ADSL over ISDN"	47
6.8 Receiver performance model for "VDSL"	49
7 Transmission and reflection models	49
7.1 Summary of test loop models	49
8 Crosstalk models	49
8.1 Basic models for crosstalk cumulation	50
8.1.1 FSAN sum for crosstalk cumulation	50

8.2	Basic models for crosstalk coupling.....	50
8.2.1	Models for equivalent NEXT and FEXT	51
8.3	Basic models for crosstalk injection.....	51
8.3.1	Forced noise injection.....	52
8.3.2	Current noise injection.....	52
8.4	Overview of different network topologies.....	53
8.5	Topology crosstalk models for two-node co-location	53
8.5.1	Basic diagram for two-node topologies	53
8.6	Topology crosstalk model for multi-node co-location	55
9	Examples of evaluating various scenarios	55
9.1	European Spectral Platform 2004 (ESP/2004).....	55
9.1.1	Technology mixtures within ESP/2004	55
9.1.2	System models within ESP/2004.....	56
9.1.3	Topology models within ESP/2004	57
9.1.4	Loop models within ESP/2004.....	60
9.1.5	Scenarios within ESP/2004.....	61
Annex A:	Bibliography	62
History.....		63

Intellectual Property Rights

IPRs essential or potentially essential to the present document may have been declared to ETSI. The information pertaining to these essential IPRs, if any, is publicly available for **ETSI members and non-members**, and can be found in ETSI SR 000 314: "*Intellectual Property Rights (IPRs); Essential, or potentially Essential, IPRs notified to ETSI in respect of ETSI standards*", which is available from the ETSI Secretariat. Latest updates are available on the ETSI Web server (<http://webapp.etsi.org/IPR/home.asp>).

Pursuant to the ETSI IPR Policy, no investigation, including IPR searches, has been carried out by ETSI. No guarantee can be given as to the existence of other IPRs not referenced in ETSI SR 000 314 (or the updates on the ETSI Web server) which are, or may be, or may become, essential to the present document.

Foreword

This Technical Report (TR) has been produced by ETSI Technical Committee Transmission and Multiplexing (TM).

The present document is part 2 of a multi-part deliverable covering Transmission and Multiplexing (TM); Access networks; Spectral management on metallic access networks, as identified below:

Part 1: "Definitions and signal library";

Part 2: "Technical methods for performance evaluations";

Part 3: "Construction Methods for Spectral Management Rules".

NOTE: Part 3 is under preparation.

1 Scope

The present document gives guidance on a common methodology for studying the impact of noise on xDSL performance (maximum reach, noise margin, maximum bitrate) when changing parameters within various Spectral Management scenarios. These methods enable reproducible results and a consistent presentation of the assumed conditions (characteristics of cables and xDSL equipment) and configuration (chosen technology mixture and cable fill) of each scenario.

The technical methods include computer models for estimating:

- xDSL receiver capability of detecting signals under noisy conditions;
- xDSL transmitter characteristics;
- cable characteristics;
- crosstalk cumulation in cables, originating from a mix of xDSL disturbers.

The *objective* is to provide the technical means for evaluating the performance of xDSL equipment within a chosen scenario. This includes the description of *performance properties* of equipment.

Another objective is to assist the reader with applying this methodology by providing examples on how to specify the *configuration* and the *conditions* of a scenario in an unambiguous way. The distinction is that a configuration of a scenario can be controlled by access rules while the conditions of a scenario cannot.

Possible applications of the present document include:

- Studying access rules, for the purpose of bounding the crosstalk in unbundled networks.
- Studying deployment rules, for the various systems present in the access network.
- Studying the impact of crosstalk on various technologies within different scenarios.

The scope of the present document is explicitly restricted to the methodology for defining scenarios and quantifying the performance of equipment within such a scenario. All judgement on what access rules are required, what performance is acceptable, or what combinations are spectral compatible, is explicitly beyond the scope of the present document. The same applies for how realistic the example scenarios are.

The models in the present document are not intended to set requirements for DSL equipment. These requirements are contained in the relevant transceiver specifications. The models in the present document are intended to provide a reasonable estimate of real-world performance but may not include every aspect of modem behaviour in real networks. Therefore real-world performance may not accurately match performance numbers calculated with these models.

2 References

For the purposes of this Technical Report (TR) the following references apply:

SpM

- [1] ETSI TR 101 830-1 (V1.3.1): "Transmission and Multiplexing (TM); Access networks; Spectral management on metallic access networks; Part 1: Definitions and signal library".
- [2] ANSI T1E1.4, T1.417-2003: "Spectrum Management for loop transmission systems".

ISDN

- [3] ETSI TS 102 080 (V1.4.1): "Transmission and Multiplexing (TM); Integrated Services Digital Network (ISDN) basic rate access; Digital transmission system on metallic local lines".

HDSL

- [4] ETSI TS 101 135 (V1.5.3): "Transmission and Multiplexing (TM); High bit-rate Digital Subscriber Line (HDSL) transmission systems on metallic local lines; HDSL core specification and applications for combined ISDN-BA and 2 048 kbit/s transmission".

SDSL

- [5] ETSI TS 101 524 (V1.3.1): "Transmission and Multiplexing (TM); Access transmission system on metallic access cables; Symmetric single pair high bitrate Digital Subscriber Line (SDSL)".
- [6] ITU-T Recommendation G.991.2 (2003): "Single-Pair High-Speed Digital Subscriber Line (SHDSL) transceivers".

ADSL

- [7] ETSI TS 101 388 (V1.3.1): "Transmission and Multiplexing (TM); Access transmission systems on metallic access cables; Asymmetric Digital Subscriber Line (ADSL) - European specific requirements [ITU-T Recommendation G.992.1 modified]".
- [8] ITU-T Recommendation G.992.1: "Asymmetric digital subscriber line (ADSL) transceivers".
- [9] ITU-T Recommendation G.992.3: "Asymmetric digital subscriber line (ADSL) transceivers - 2 (ADSL2)".

VDSL

- [10] ETSI TS 101 270-1 (V1.3.1): "Transmission and Multiplexing (TM); Access transmission systems on metallic access cables; Very high speed Digital Subscriber Line (VDSL); Part 1: Functional requirements".

SPLITTERS

- [11] ETSI TS 101 952-1-3 (V1.1.1): "Access network xDSL transmission filters; Part 1: ADSL splitters for European deployment; Sub-part 3: Specification of ADSL/ISDN splitters".
- [12] ETSI TS 101 952-1-4 (V1.1.1): "Access network xDSL transmission filters; Part 1: ADSL splitters for European deployment; Sub-part 4: Specification of ADSL over "ISDN or POTS" universal splitters".

3 Definitions and abbreviations

3.1 Definitions

For the purposes of the present document, the following terms and definitions apply:

access port: is the physical location, appointed by the loop provider, where signals (for transmission purposes) are injected into the local loop wiring

access rule: mandatory rule for achieving access to the local loop wiring, equal for all network operators who are making use of the same network cable that bounds the crosstalk in that network cable

cable fill (or degree of penetration): number and mixture of transmission techniques connected to the ports of a binder or cable bundle that are injecting signals into the access ports

Cable Management Plan (CMP): list of selected access rules dedicated to a specific network

NOTE: This list may include associated descriptions and explanations.

deployment rule: voluntary rule, irrelevant for achieving access to the local loop wiring and proprietary to each individual network operator

NOTE: A deployment rule reflects a network operator's own view about what the maximum length or maximum bitrate may be for offering a specific transmission service to ensure a chosen minimum quality of service.

disturber: source of interference in spectral management studies coupled to the wire pair connecting victim modems

NOTE: This term is intended solely as a technical term, defined within the context of these studies, and is not intended to imply any negative judgement.

downstream transmission: transmission direction from port, labelled as LT-port, to a port, labelled as NT-port

NOTE: This direction is usually from the central office side via the local loop wiring, to the customer premises.

Echo Cancelled (EC): term used within the context of ADSL to designate ADSL systems with spectral overlap of downstream and upstream signals

NOTE: In this context, the usage of the abbreviation "EC" was only kept for historical reasons. The usage of the echo cancelling technology is not only limited to spectrally overlapped systems, but can also be used by FDD systems.

local loop wiring: part of a metallic access network, terminated by well-defined ports, for transporting signals over a distance of interest

NOTE: This part includes mainly cables, but may also include a Main Distribution Frame (MDF), street cabinets, and other distribution elements. The local loop wiring is usually passive only, but may include active splitter-filters as well.

loop provider: organization facilitating access to the local loop wiring

NOTE: In several cases the loop provider is historically connected to the incumbent network operator, but other companies may serve as loop provider as well.

LT-access port (or LT-port for short): is an access port for injecting signals, designated as "LT-port"

NOTE: Such a port is commonly located at the central office side, and intended for injecting "downstream" signals.

max data rate: maximum data rate that can be recovered according to predefined quality criteria, when the received noise is increased with a chosen noise margin (or the received signal is decreased with a chosen signal margin)

network operator: organization that makes use of a local loop wiring for transporting telecommunication services

NOTE: This definition covers incumbent as well as competitive network operators.

noise margin: ratio (P_{n2}/P_{n1}) by which the received noise power P_{n1} may increase to power P_{n2} until the recovered signal no longer meets the predefined quality criteria

NOTE: This ratio is commonly expressed in dB.

NT-access port (or NT-port for short): is an access port for injecting signals, designated as "NT-port"

NOTE: Such a port is commonly located at the customer premises, and intended for injecting "upstream" signals.

performance: is a measure of how well a transmission system fulfils defined criteria under specified conditions

NOTE: Such criteria include reach, bitrate and noise margin.

power back-off: is a generic mechanism to reduce the transmitter's output power

NOTE: It has many purposes, including the reduction of power consumption, receiver dynamic range, crosstalk, etc.

power cut-back: a specific variant of power back-off, used to reduce the dynamic range of the receiver, that is characterized by a frequency independent reduction of the in-band PSD

NOTE: It is used, for instance, in ADSL and SDSL.

PSD mask: The absolute upper bound of a PSD, measured within a specified resolution band

NOTE: The purpose of PSD masks is usually to specify maximum PSD levels for stationary signals.

PSD template: The expected average PSD of a stationary signal

NOTE: The purpose of PSD templates is usually to perform simulations. The levels are usually below or equal to the associated PSD masks.

signal category: is a class of signals meeting the minimum set of specifications identified in TR 101 830-1 [1]

NOTE: Some signal categories may be distinct between different sub-classes, and may label them for instance as signals for "downstream" or for "upstream" purposes.

signal margin: ratio (P_{s1}/P_{s2}) by which the received signal power P_{s1} may decrease to power P_{s2} until the recovered signal no longer meets the predefined quality criteria

NOTE: This ratio is commonly expressed in dB.

spectral compatibility: generic term for the capability of transmission systems to operate in the same cable

NOTE: The precise definition is application dependent and has to be defined for each group of applications.

spectral management: art of making optimal use of limited capacity in (metallic) access networks

NOTE: This is for the purpose of achieving the highest reliable transmission performance and includes:

- § Designing of deployment rules and their application.
- § Designing of effective access rules.
- § Optimized allocation of resources in the access network, e.g. access ports, diversity of systems between cable bundles, etc.
- § Forecasting of noise levels for fine-tuning the deployment.
- § Spectral policing to enforce compliance with access rules.
- § Making a balance between conservative and aggressive deployment (low or high failure risk).

spectral management rule: generic term, incorporating (voluntary) deployment rules, (mandatory) access rules and all other (voluntary) measures to maximize the use of local loop wiring for transmission purposes

transmission equipment: equipment connected to the local loop wiring that uses a transmission technique to transport information

transmission system: set of transmission equipment that enables information to be transmitted over some distance between two or more points

transmission technique: electrical technique used for the transportation of information over electrical wiring

upstream transmission: transmission direction from a port, labelled as NT-port, to a port, labelled as LT-port

NOTE: This direction is usually from the customer premises, via the local loop wiring, to the central office side.

victim modem: modem, subjected to interference (such as crosstalk from all other modems connected to other wire pairs in the same cable) that is being studied in a spectral management analysis

NOTE: This term is intended solely as a technical term, defined within the context of these studies, and is not intended to imply any negative judgement.

3.2 Abbreviations

For the purposes of the present document, the following abbreviations apply:

2B1Q	2-Binary, 1-Quaternary (Use of 4-level PAM to carry two bits per pulse)
ADSL	Asymmetric Digital Subscriber Line
BER	Bit Error Ratio
CAP	Carrier less Amplitude/Phase modulation
CMP	Cable Management Plan
DFE	Decision Feedback Equalizer
DMT	Discrete MultiTone modulation
EC	Echo Cancelled
EPL	Estimated Power Loss
FBL	Fractional Bit Loading
FDD	Frequency Division Duplexing/Duplexed
FSAN	Full Service Access Network
GABL	Gain Adjusted Bit Loading
HDSL	High bitrate Digital Subscriber Line
ISDN	Integrated Services Digital Network
LT-port	Line Termination - port (<i>commonly at central office side</i>)
LTU	Line Termination Unit
MDF	Main Distribution Frame
NT-port	Network Termination - port (<i>commonly at customer side</i>)
NTU	Network Termination Unit
PAM	Pulse Amplitude Modulation
PBO	Power Back-Off
PSD	Power Spectral Density (single sided)
QAM	Quadrature Amplitude Modulation
RBL	Rounded Bit Loading
SDSL	Symmetrical (single pair high bitrate) Digital Subscriber Line
SNR	Signal to Noise Ratio (<i>ratio of powers</i>)
TBL	Truncated Bit Loading
TRA	TRAnsmmitter
UC	Ungerboeck Coded (also known as trellis coded)
VDSL	Very-high-speed Digital Subscriber Line
xDSL	(all systems) Digital Subscriber Line

4 Transmitter signal models for xDSL

A transmitter model in this clause is mainly a PSD description of the transmitted signal under matched conditions, plus an output impedance description to cover mismatched conditions as well.

PSD *masks* of transmitted xDSL signals are specified in several documents for various purposes, for instance in TR 101 830-1 [1]. These PSD masks, however, cannot be applied directly to the description of a transmitter model. One reason is that masks are specifying an upper limit, and not the expected (averaged) values. Another reason is that the definition of the true PSD of a time-limited signal requires no resolution bandwidth at all (it is defined by means of an autocorrelation, followed by a Fourier transform) while PSD *masks* do rely on some resolution bandwidth. They describe values that are (slightly) different from the true PSD; especially at steep edges (e.g. guard bands), and for modelling purposes this difference is sometimes very relevant.

To differentiate between several PSD descriptions, *masks* and *templates* of a PSD are given a different meaning. Masks are intended for proving compliance to standard requirements, while templates are intended for modelling purposes. This clause summarizes various xDSL transmitter models, by defining *template* spectra of output signals.

In some cases, models are marked as "default" and/or as "alternative". Both models are applicable, but in case a preference of either of them does not exist, the use of the "default" models is recommended. Other (alternative) models may apply as well, provided that they are specified.

4.1 Generic transmitter signal model

A generic model of an xDSL transmitter is essentially a linear signal source. The Thevenin equivalent of such a source equals an ideal voltage source U_s having a real resistor R_s in series. The output voltage of this source is random in nature (as a function of the time), and occupies a relatively broad spectrum. Correlation between transmitters is taken to be negligible. The autocorrelation properties of a transmitter's signal are taken to be adequately represented by a PSD template.

This generic model can be made specific by defining:

- The output impedance R_s of the transmitter.
- The template of the PSD, measured at the output port, when terminated with an external impedance equal to R_s . This is identified as the "matched condition", and under this condition the output power equals the maximum power that is available from this source. Under all other (mis-matched) termination conditions the output power will be lower.

4.2 Transmitter signal model for "ISDN.2B1Q"

The PSD template for modelling the "ISDN.2B1Q" transmit spectrum is defined by the theoretical sinc-shape of PAM encoded signals, with additional filtering and with a noise floor. The PSD is the maximum of both power density curves, as summarized in expression 1 and the associated table 1. The coefficient q_N scales the total signal power of $P_1(f)$ to a value that equals P_{ISDN} . This value is dedicated to the used filter characteristics, but equals $q_N=1$ when no filtering is applied ($f_L \rightarrow 0, f_H \rightarrow \infty$). The source impedance equals 135Ω .

$P_1(f) = P_{ISDN} \times \frac{2 \times q_N}{f_x} \times \text{sinc}^2\left(\frac{f}{f_x}\right) \times \frac{1}{1 + \left(\frac{f}{f_H}\right)^{2 \cdot N_H}} \times \frac{1}{1 + \left(\frac{f_L}{f}\right)^2} \quad [W / Hz]$
$P_2(f) = \frac{10^{(P_{\text{floor_dBm}}/10)}}{1000} \quad [W / Hz]$
$P(f) = \max(P_1(f), P_2(f)) \quad [W / Hz]$
<p>Where:</p> $P_{ISDN} = \left(10^{P_{ISDN_dBm}/10}\right) / 1000 \quad [W]$ $R_s = 135 \quad [\Omega]$ $\text{sinc}(x) = \sin(\pi \cdot x) / (\pi \cdot x)$ <p><i>Default values for remaining parameters are summarized in table 1.</i></p>

Expression 1: PSD template for modelling "ISDN.2B1Q" signals

Different ISDN implementations, may use different filter characteristics, and noise floor values. Table 1 specifies *default* values for ISDN implementations, in the case where 2nd order Butterworth filtering has been applied. The default noise floor equals the maximum PSD level that meets the out-of-band specification of the ISDN standard (TS 102 080 [3]).

Table 1: Default parameter values for the ISDN.2B1Q templates, as defined in expression 1 - These default values are based on 2nd order Butterworth filtering

Type	f_x [kHz]	f_H [kHz]	f_L [kHz]	N_H	q_N	P_{ISDN_dBm} [dBm]	$P_{\text{floor_dBm}}$ [dBm/Hz]
ISDN.2B1Q	80	$1 \times f_x$	0	2	1,1257	13,5	-120

4.3 Transmitter signal model for "ISDN.2B1Q/filtered"

When ISDN signals have to pass a low-pass filter (such as in an ADSL splitter) before they reach the line, the disturbance caused by these ISDN systems to other wire pairs will change, as well as their performance. SpM studies should therefore make a distinction between crosstalk generated from ISDN systems connected directly to the line and filtered ISDN systems.

The PSD template for modelling a "ISDN.2B1Q/filtered" transmitter signal that has passed a low-pass splitter/filter, is defined in table 2 in terms of break frequencies. It has been constructed from the transmitter PSD template, filtered by the low-pass transfer function representing the splitter/filter.

The values are based on filter assumptions according to splitter specifications in TS 101 952-1-3 [11] and TS 101 952-1-4 [12]. The associated values are constructed with straight lines between these break frequencies, when plotted against a *logarithmic* frequency scale and a *linear* dBm scale.

Table 2: PSD template for modelling "ISDN.2B1Q/filtered" signals

ISDN.2B1Q/filtered	(135W)
f [Hz]	P [dBm/Hz]
1 k	-32,1
10 k	-32,3
20 k	-33,1
30 k	-34,5
40 k	-36,6
50 k	-39,8
60 k	-44,5
65 k	-47,8
70 k	-52,2
75 k	-59,3
80 k	-126,5
85 k	-61,9
90 k	-57,4
100 k	-55,2
110 k	-57,9
115 k	-62,9
120 k	-68,2
125 k	-79,3
130 k	-90,8
135 k	-104,1
140 k	-117,9
145 k	-132,8
150 k	-136,9
160 k	-140,0
170 k	-140,0
180 k	-136,2
190 k	-135,2
200 k	-135,8
210 k	-137,8
220 k	-140,0
30 M	-140,0

4.4 Line-shared signal model for "ISDN.2B1Q"

The PSD template for modelling the line-shared signal from an ISDN.2B1Q transmitter that has passed the low-pass and the high-pass part of a splitter/filter for sharing the line with ADSL signals, is defined in table 3 in terms of break frequencies. It has been constructed from the transmitter PSD template, filtered by the low-pass and the high-pass transfer function representing the splitter/filter.

The values are based on filter assumptions according to splitter specifications in TS 101 952-1-3 [11] and in TS 101 952-1-4 [12]. The associated values are constructed with straight lines between these break frequencies, when plotted against a *logarithmic* frequency scale and a *linear* dBm scale.

Table 3: PSD template for modelling line shared "ISDN.2B1Q" signals

Line-shared ISDN.2B1Q	(135W)
f [Hz]	P [dBm/Hz]
1 k	-40,1
10 k	-40,3
20 k	-41,0
30 k	-42,2
40 k	-44,1
50 k	-46,8
60 k	-51,1
65 k	-54,2
70 k	-58,3
75 k	-65,1
80 k	-127,0
85 k	-66,9
90 k	-61,9
100 k	-59,0
110 k	-61,2
115 k	-65,9
120 k	-70,9
125 k	-81,7
130 k	-93,0
135 k	-106,1
140 k	-119,4
145 k	-134,1
150 k	-138,0
160 k	-140,0
170 k	-140,0
180 k	-137,2
190 k	-136,2
200 k	-136,8
210 k	-138,8
220 k	-140,0
30 M	-140,0

4.5 Transmitter signal model for "ISDN.MMS43"

The PSD template for modelling the "ISDN.MMS43" transmit spectrum (also known as ISDN.4B3T) is defined by a combination of a theoretical curve and a noise floor. The PSD is the maximum of both power density curves, as summarized in expression 2. The source impedance equals 150 Ω .

$$P_1(f) = P_{ISDN} \times \frac{2}{f_0} \times \left[\text{sinc}^2\left(\frac{f}{f_0}\right) + \text{sinc}^2\left(\frac{f - f_{P1}}{f_0}\right) + \text{sinc}^2\left(\frac{f - f_{P2}}{f_0}\right) \right] \times \frac{1}{1 + \left(\frac{f}{f_{L1}}\right)^4} \times \frac{1}{1 + \left(\frac{f}{f_{L2}}\right)^4} \quad [W / Hz]$$

$$P(f) = P_1(f) + P_{floor} \quad [W / Hz]$$

Where:

$$P_{ISDN} = \left(10^{P_{ISDN_dBm}/10}\right) / 1000 \quad [W], \quad P_{ISDN_dBm} = 13,5 \text{ dBm}$$

$$P_{floor} = \left(10^{P_{floor_dBm}/10}\right) / 1000 \quad [W/Hz], \quad P_{floor_dBm} = -125 \text{ dBm/Hz}$$

$$f_0 = 120 \text{ kHz}; \quad f_{P1} = 1020 \text{ kHz}; \quad f_{P2} = 1860 \text{ kHz}; \quad f_{L1} = 80 \text{ kHz}; \quad f_{L2} = 1020 \text{ kHz};$$

$$\text{sinc}(x) = \sin(\pi \cdot x) / (\pi \cdot x)$$

Expression 2: PSD template for modelling "ISDN.MMS43" signals

4.6 Transmitter signal model for "ISDN.MMS43/filtered"

When ISDN signals have to pass a low-pass filter (such as in an ADSL splitter) before they reach the line, the disturbance caused by these ISDN systems to other wire pairs will change, as well as their performance. SpM studies should therefore make a distinction between crosstalk generated from ISDN systems connected directly to the line and filtered ISDN systems.

The PSD template for modelling a "ISDN.MMS43/filtered" transmitter signal that has passed a low-pass splitter/filter, is defined in table 4 in terms of break frequencies. It has been constructed from the transmitter PSD template, filtered by the low-pass transfer function representing the splitter/filter.

The values are based on filter assumptions according to splitter specifications in TS 101 952-1-3 [11] and in TS 101 952-1-4 [12]. The associated values are constructed with straight lines between these break frequencies, when plotted against a *logarithmic* frequency scale and a *linear* dBm scale.

Table 4: PSD template for modelling "ISDN.MMS.43/filtered" signals

ISDN.MMS.43/filtered	(150 W)
f [Hz]	P [dBm/Hz]
1 k	-34,5
10 k	-34,6
20 k	-35,0
30 k	-35,7
40 k	-36,7
50 k	-38,2
60 k	-40,2
70 k	-42,8
80 k	-46,2
90 k	-50,8
100 k	-56,8
110 k	-66,8
115 k	-80,3
120 k	-93,6
125 k	-106,9
130 k	-112,4
135 k	-122,5
140 k	-131,4
150 k	-130,4
170 k	-129,8
190 k	-132,7
200 k	-134,8
210 k	-137,6
216 k	-140,0
30 M	-140,0

4.7 Line-shared signal model for "ISDN.MMS43"

The PSD template for modelling the line-shared signal from an ISDN.MMS43 transmitter (also known as vv ISDN.4B3T), that has passed the low-pass and the high-pass part of a splitter/filter for sharing the line with ADSL signals, is defined in table 5 in terms of break frequencies. It has been constructed from the transmitter PSD template, filtered by the low-pass and the high-pass transfer function representing the splitter/filter.

The values are based on filter assumptions according to splitter specifications in TS 101 952-1-3 [11] and in TS 101 952-1-4 [12]. The associated values are constructed with straight lines between these break frequencies, when plotted against a *logarithmic* frequency scale and a *linear* dBm scale.

Table 5: PSD template for modelling line shared "ISDN.MMS.43" signals

Line-shared ISDN.MMS.43	(150 W)
f [Hz]	P [dBm/Hz]
1 k	-42,5
10 k	-42,6
20 k	-42,9
30 k	-43,4
40 k	-44,2
50 k	-45,3
60 k	-46,8
70 k	-48,9
80 k	-51,7
90 k	-55,3
100 k	-60,6
110 k	-70,1
115 k	-83,0
120 k	-96,0
125 k	-109,1
130 k	-114,3
135 k	-124,0
140 k	-132,7
150 k	-131,5
170 k	-130,8
190 k	-133,7
200 k	-135,8
210 k	-138,6
216 k	-140,0
30 M	-140,0

4.8 Transmitter signal model for "HDSL.2B1Q"

The PSD templates for modelling the spectra of various "HDSL.2B1Q" transmitters are defined by the theoretical sinc-shape of PAM encoded signals, with additional filtering and a noise floor. The PSD template is the maximum of both power density curves, as summarized in expression 3 and associated table 6.

The coefficient q_N scales the total signal power of $P_1(f)$ to a value that equals P_0 . This value is dedicated to the filter characteristics used, but equals $q_N=1$ when no filtering is applied ($f_L \rightarrow 0, f_H \rightarrow \infty$). The source impedance equals 135 Ω .

$$P_1(f) = P_{HDSL} \times \frac{2 \times q_N}{f_X} \times \text{sinc}^2\left(\frac{f}{f_X}\right) \times \frac{1}{1 + \left(\frac{f_L}{f}\right)^2} \times \frac{1}{1 + \left(\frac{f}{f_{H1}}\right)^{2 \cdot N_{H1}}} \times \frac{1}{1 + \left(\frac{f}{f_{H2}}\right)^{2 \cdot N_{H2}}} \quad [W / Hz]$$

$$P_2(f) = \frac{10^{(P_{\text{floor_dBm}}/10)}}{1000} \quad [W / Hz]$$

$$P(f) = \max(P_1(f), P_2(f)) \quad [W / Hz]$$

Where:

$$P_{HDSL} = \left(10^{P_{HDSL_dBm}/10}\right) / 1000 \quad [W]$$

$$R_S = 135 \quad [\Omega]$$

$$\text{sinc}(x) = \sin(\pi \cdot x) / (\pi \cdot x)$$

Default values for remaining parameters are summarized in table 6.

Expression 3: PSD template for modelling "HDSL.2B1Q" signals

Different HDSL implementations, may use different filter characteristics, and noise floor values. Table 6 summarizes *default* values for modelling HDSL transmitters (name starting with a "D"), as well as *alternative* values (name starting with an "A"). The power level P_{HDSL} equals the maximum power allowed by the HDSL standard (TS 101 135 [4]), since a nominal value does not exist in that standard. The noise floor P_{floor} equals a value observed for various implementations of HDSL.2B1Q/2, and assumed to be valid for other HDSL.2B1Q variants too.

Table 6: Parameter values for the HDSL.2B1Q templates, as defined in expression 3

Model	Type	f_x kHz	f_L kHz	f_{H1}	N_{H1}	f_{H2}	N_{H2}	q_N	$P_{\text{HDSL_dBm}}$ dBm	$P_{\text{floor_dBm}}$ dBm/Hz
D1	HDSL.2B1Q/1	1 160	3	$0,42 \times f_x$	3	N/A	N/A	1,4662	14	-133
D2	HDSL.2B1Q/2	584	3	$0,68 \times f_x$	4	N/A	N/A	1,1915	14	-133
A2.1	HDSL.2B1Q/2	584	3	$0,50 \times f_x$	3	N/A	N/A	1,3501	14	-133
A2.2	HDSL.2B1Q/2	584	3	$0,68 \times f_x$	4	$1,50 \times f_x$	2	1,1965	14	-133
D3	HDSL.2B1Q/3	392	3	$0,50 \times f_x$	3	N/A	N/A	1,3642	14	-133
NOTE: The alternative values are based on higher order Butterworth filtering. Choose $f_{H2}=\infty$ and $N_{H2}=1$ when not applicable (N/A).										

NOTE: Model A2.1 assumes a minimum amount of filtering that is required to meet the transmit specifications in TS 101 135 [4]. Model D2 outperforms these transmit requirements by assuming the application of higher order filtering. Nevertheless, model D2 is identified as a "default" model, instead of A2.1, because it has been demonstrated that several commonly used chipsets have implemented this additional filtering. When spectral compatibility studies show that model D2 is significantly friendlier to other systems in the cable than model A2.1, it is recommended to verify that model D2 is adequate for the HDSL modem under study.

4.9 Transmitter signal model for "HDSL.CAP"

The PSD templates for modelling signals generated by HDSL.CAP transmitters are different for single-pair and two-pair HDSL systems. The PSD templates for modelling the "HDSL.CAP/1" transmit spectra for one-pair systems and "HDSL.CAP/2" transmit spectra for two-pair systems are defined in terms of break frequencies, as summarized in table 7. These templates are taken from the nominal shape of the transmit signal spectra, as specified in the ETSI HDSL standard (TS 101 135 [4]).

The associated values are constructed with straight lines between these break frequencies, when plotted against a *logarithmic* frequency scale and a *linear* dBm scale. The source impedance equals $R_s = 135 \Omega$.

Table 7: PSD template values at break frequencies for modelling "HDSL.CAP"

HDSL.CAP/1		1-pair 135 W	HDSL.CAP/2		2-pair 135 W
[Hz]	[dBm/Hz]		[Hz]	[dBm/Hz]	
1	-57		1	-57	
4,0 k	-57		3,98 k	-57	
33 k	-43		21,5 k	-43	
62 k	-40		39,02 k	-40	
390,67 k	-40		237,58 k	-40	
419,67 k	-43		255,10 k	-43	
448,67 k	-60		272,62 k	-60	
489,02 k	-70		297,00 k	-70	
1 956,08 k	-120		1,188 M	-120	
30 M	-120		30 M	-120	
NOTE: The out-of-band values may be lower than specified in these models.					

4.10 Transmitter signal model for "SDSL"

The PSD templates for modelling the spectra of "SDSL" transmitters are defined by the theoretical sinc-shape of PAM encoded signals, plus additional filtering and a noise floor. The transmit spectrum is defined as summarized in expression 4 and the associated table 8.

NOTE: These models are applicable to SDSL 16-UC-PAM at rates up to 2,312 Mb/s.

This PSD template is taken from the nominal shape of the transmit signal spectrum, as specified in the ETSI SDSL standard (TS 101 524 [5]). The source impedance equals $R_s=135\Omega$.

$P_{sinc}(f) = \frac{K_{sdsl}}{R_s \times f_x} \times \text{sinc}^2\left(\frac{f}{f_x}\right) \times \frac{1}{1 + \left(\frac{f}{f_H}\right)^{2 \cdot N_H}} \times \frac{1}{1 + \left(\frac{f_L}{f}\right)^2} \quad [W / Hz]$
$P_{floor}(f) = \frac{10^{(P_{floor_dBm}/10)}}{1000} \quad [W / Hz]$
$P_{SDSL}(f) = P_{sinc} + P_{floor} \quad [W / Hz]$
$R_s = 135 \Omega$ $P_{floor} = -120 \text{ dBm/Hz}$ $\text{sinc}(x) = \sin(\pi \cdot x) / (\pi \cdot x)$ <i>Parameter values are defined in table 8</i>

Expression 4: PSD template values for modelling both the symmetric and asymmetric modes of SDSL

Table 8: Parameter values for the SDSL templates, as defined in expression 4

Mode	Data Rate R [kb/s]	TRA	Symbol Rate f_{sym} [kbaud]	f_x	f_H	f_L [kHz]	f_0 [Hz]	N_H	K_{SDSL} [V ²]	K_x [W/Hz]
Sym	< 2 048	both	$(R+ 8 \text{ kbit/s})/3$	f_{sym}	$f_x/2$	5	1	6	7,86	$0,5683 \times 10^{-4}$
Sym	$\geq 2 048$	both	$(R+ 8 \text{ kbit/s})/3$	f_{sym}	$f_x/2$	5	1	6	9,90	$0,5683 \times 10^{-4}$
Asym	2 048	LTU	$(R+ 8 \text{ kbit/s})/3$	$2 \times f_{sym}$	$f_x \times 2/5$	5	1	7	16,86	$0,5683 \times 10^{-4}$
Asym	2 048	NTU	$(R+ 8 \text{ kbit/s})/3$	f_{sym}	$f_x \times 1/2$	5	1	7	15,66	$0,5683 \times 10^{-4}$
Asym	2 304	LTU	$(R+ 8 \text{ kbit/s})/3$	$2 \times f_{sym}$	$f_x \times 3/8$	5	1	7	12,48	$0,5683 \times 10^{-4}$
Asym	2 304	NTU	$(R+ 8 \text{ kbit/s})/3$	f_{sym}	$f_x \times 1/2$	5	1	7	11,74	$0,5683 \times 10^{-4}$

Power back-off (both directions)

The SDSL transmitter signal model includes a mechanism to cutback the power for short loops, and will be activated when the "Estimated Power Loss" (EPL) of the loop is below a threshold loss PL_{thres} . This EPL is defined as the ratio between the total transmitted power (in W), and the total received power (in W). This loss is usually expressed in dB as EPL_{dB} .

This power back-off (PBO) is equal for all in-band transmit frequencies, and is specified in expression 5. It should be noted that this model is based on a smooth cutback mechanism, although practical SDSL modems may cut back their power in discrete steps ("staircase"). This expression is simplified for simulation purposes. The SDSL power back-off is described in TS 101 524 [5], clause 9.2.6.

$$PBO_{dB} = \begin{cases} 0dB & (if \Delta_{PL} < 0) \\ \Delta_{PL} & (if 0 \leq \Delta_{PL} \leq 6dB) \\ 6dB & (if \Delta_{PL} > 6dB) \end{cases} \quad \text{where } \Delta_{PL} = (PL_{thres,dB} - EPL_{dB})$$

Expression 5: Power back-off of the transmitted signal (in both directions), as a function of the Estimated Power Loss (EPL) and a threshold loss of $PL_{thres,dB} = 6,5 \text{ dB}$, and represents some average of the "staircase"

4.11 Transmitter signal model for "EC ADSL over POTS"

The PSD template for modelling the "EC ADSL over POTS" (TS 101 388 [7]) transmit spectrum (EC variant) is defined in terms of break frequencies, as summarized in table 9. The associated values are constructed with straight lines between these break frequencies, when plotted against a *logarithmic* frequency scale and a *linear* dBm scale. The frequency Δf in this table refers to the spacing of the DMT sub carriers of ADSL. The source impedance equals $R_s = 100 \Omega$.

NOTE: These models do not apply to the associated ADSL2 (annex A) variant (ITU-T Recommendation G.992.3 [9]).

Table 9: PSD template values at break frequencies for modelling "EC ADSL over POTS"

EC ADSL over POTS DMT carriers		Up [7:31]	EC ADSL over POTS DMT carriers		Down [7:255]
f [Hz]		P [dBm/Hz]	f [Hz]		P [dBm/Hz]
0		-101	0		-101
3,99k		-101	3,99 k		-101
4 k		-96	4 k		-96
$6,5 \times \Delta f$ ($\approx 28,03$ k)		-38	$6,5 \times \Delta f$ ($\approx 28,03$ k)		-40
$31,5 \times \Delta f$ ($\approx 135,84$ k)		-38	$256 \times \Delta f$ ($\approx 1\,104$ k)		-40
$53,0 \times \Delta f$ ($\approx 228,56$ k)		-90	1,250 M		-45
686 k		-100	1,500 M		-70
1,411 M		-100	2,100 M		-90
1,630 M		-110	3,093 M		-90
5,275 M		-112	4,545 M		-112
30 M		-112	30 M		-112
$\Delta f = 4,3125$ kHz			$\Delta f = 4,3125$ kHz		

Power cut back (downstream only)

The transmitter signal model includes a mechanism to cut-back the power for short loops, and will be activated when the band-limited power P_{rec} , received within a specified frequency band at the other side of the loop, exceeds a threshold value P_{thres} . This frequency band is from $6,5 \times \Delta f$ to $18,5 \times \Delta f$, where $\Delta f = 4,3125$ kHz, and covers 12 consecutive sub carriers (7 through 18).

The cut back mechanism reduces the PSD template to a level PSD_{max} , as specified in expression 6, for those frequencies where the downstream PSD template exceeds this level. For all other frequencies, the PSD template remains unchanged. Note that this model is based on a smooth cutback mechanism, although practical ADSL modems may cut back their power in discrete steps ("staircase").

$$PSD_{max, dBm} = \begin{cases} -40 \text{ dBm/Hz} & (\text{if } \Delta_p < 0 \text{ dB}) \\ -40 \text{ dBm/Hz} - 2 \times \Delta_p & (\text{if } 0 \leq \Delta_p \leq 6 \text{ dB}) \\ -52 \text{ dBm/Hz} & (\text{if } \Delta_p > 6 \text{ dB}) \end{cases} \quad \text{where } \Delta_p = (P_{rec, dBm} - P_{thres, dBm})$$

Expression 6: Maximum PSD values of the transmitted downstream signal, as a function of the band-limited received power P_{rec} and a threshold level of $P_{thres, dBm} = 2,5$ dBm, and represents some average of the "staircase"

4.12 Transmitter signal model for "FDD ADSL over POTS"

The PSD template for modelling "FDD ADSL over POTS" (TS 101 388 [7] and ITU-T Recommendation G.992.1 [8]) transmit spectra is defined in terms of break frequencies, as summarized in tables 11 and 10.

- Table 10 is to be used for modelling "adjacent FDD modems", usually enhanced by echo cancellation for improving the separation between upstream and downstream signals. Because a guard band is not needed here, only 1 sub-carrier is left unused.

- Table 11 is to be used for modelling "guard band FDD modems", usually equipped with steep filtering for improving the separation between upstream and downstream signals. 7 sub-carriers are left unused to enable this guard band to be implemented.

The associated values are constructed with straight lines between these break frequencies, when plotted against a *logarithmic* frequency scale and a *linear* dBm scale. The frequency Δf in this table refers to the spacing of the DMT sub-carriers of ADSL. The source impedance equals $R_s = 100 \Omega$.

NOTE: These models do not apply to the associated ADSL2 (annex A) variant (ITU-T Recommendation G.992.3 [9]).

Table 10: PSD template values at break frequencies for modelling "FDD ADSL over POTS", implemented as "adjacent FDD" (with echo cancelling)

Adjacent FDD (using echo cancellation)				
FDD ADSL over POTS DMT carriers		Up [7:31]	FDD ADSL over POTS DMT carriers	
f [Hz]		P [dBm/Hz]	Down [33:255]	
f [Hz]		P [dBm/Hz]	f [Hz]	
0	-101	0	-101	
3,99k	-101	3,99 k	-101	
4 k	-96	4 k	-96	
6,5 $\times\Delta f$ ($\approx 28,03$ k)	-38	22,5 $\times\Delta f$ ($\approx 97,03$ k)	-96	
31,5 $\times\Delta f$ ($\approx 135,84$ k)	-38	32,0 $\times\Delta f$ ($\approx 138,00$ k)	-47,7	
41,5 $\times\Delta f$ ($\approx 178,97$ k)	-90	32,5 $\times\Delta f$ ($\approx 140,16$ k)	-40	
686 k	-100	256 $\times\Delta f$ (= 1 104 k)	-40	
1,411 M	-100	1,250 M	-45	
1,630 M	-110	1,500 M	-70	
5,275 M	-112	2,100 M	-90	
30 M	-112	3,093 M	-90	
		4,545 M	-112	
		30 M	-112	
$\Delta f = 4,3125$ kHz		$\Delta f = 4,3125$ kHz		
NOTE: This PSD allocates 1 unused sub carrier, since a guard band is not required here.				

Table 11: PSD template values at break frequencies for modelling "FDD ADSL over POTS", implemented as "guard band FDD" (with filtering)

Guard band FDD (using filters)				
FDD ADSL over POTS DMT carriers		Up [7:30]	FDD ADSL over POTS DMT carriers	
f [Hz]		P [dBm/Hz]	Down [38:255]	
f [Hz]		P [dBm/Hz]	f [Hz]	
0	-101	0	-101	
3,99k	-101	3,99 k	-101	
4 k	-96	4 k	-96	
6,5 $\times\Delta f$ ($\approx 28,03$ k)	-38	27,5 $\times\Delta f$ ($\approx 118,59$ k)	-96	
30,5 $\times\Delta f$ ($\approx 131,53$ k)	-38	37,0 $\times\Delta f$ ($\approx 159,56$ k)	-47,7	
40,5 $\times\Delta f$ ($\approx 174,66$ k)	-90	37,5 $\times\Delta f$ ($\approx 161,72$ k)	-40	
686 k	-100	256 $\times\Delta f$ (= 1 104 k)	-40	
1,411 M	-100	1,250 M	-45	
1,630 M	-110	1,500 M	-70	
5,275 M	-112	2,100 M	-90	
30 M	-112	3,093 M	-90	
		4,545 M	-112	
		30 M	-112	
$\Delta f = 4,3125$ kHz		$\Delta f = 4,3125$ kHz		
NOTE: This PSD allocates 7 unused sub-carriers.				

Power cut back (downstream only)

The transmitter signal model includes a mechanism to cut back the power for short loops, using the same mechanism as specified in expression 6, for modelling "EC ADSL over POTS" transmitters.

4.13 Transmitter signal model for "EC ADSL over ISDN"

The PSD template for modelling the "EC ADSL over ISDN" (TS 101 388 [7] and ITU-T Recommendation G.992.1 [8]) transmit spectrum (EC variant) is defined in terms of break frequencies, as summarized in table 12. The associated values are constructed with straight lines between these break frequencies, when plotted against a *logarithmic* frequency scale and a *linear* dBm scale. The frequency Δf in this table refers to the spacing of the DMT sub-carriers of ADSL. The source impedance equals $R_s = 100 \Omega$.

NOTE: These models do not apply to the associated ADSL2 (annex B) variant (ITU-T Recommendation G.992.3 [9]).

Table 12: PSD template values at break frequencies for modelling "EC ADSL over ISDN"

EC ADSL over ISDN DMT carriers		Up [33:63]		EC ADSL over ISDN DMT carriers		Down [33:255]	
f [Hz]		P [dBm/Hz]		f [Hz]		P [dBm/Hz]	
0		-90		0		-90	
50		-90		50 k		-90	
22,5×Δf (≈ 97,03 k)		-85,3		22,5×Δf (≈ 97,03 k)		-85,3	
32,5×Δf (≈ 140,16 k)		-38		32,5×Δf (≈ 140,16 k)		-40	
63,5×Δf (≈ 273,84 k)		-38		256×Δf (= 1 104 k)		-40	
67,5×Δf (≈ 291,09 k)		-55		1,250 M		-45	
74,5×Δf (≈ 321,28 k)		-60		1,500 M		-70	
80,5×Δf (≈ 347,16 k)		-97,8		2,100 M		-90	
686 k		-100		3,093 M		-90	
1,411 M		-100		4,545 M		-112	
1,630 M		-110		30 M		-112	
5,275 M		-112					
30 M		-112					
Δf = 4,3125 kHz				Δf = 4,3125 kHz			

Power cut back (downstream only)

The transmitter signal model includes a mechanism to cut-back the power for short loops, and will be activated when the band-limited power P_{rec} , received within a specified frequency band at the other side of the loop, exceeds a threshold value P_{thres} . This frequency band is from $35.5 \times \Delta f$ to $47.5 \times \Delta f$, where $\Delta f = 4.3125$ kHz, and covers 12 consecutive sub carriers (36 through 47).

The cut back mechanism reduces the PSD template to a level PSD_{max} , as specified in expression 7, for those frequencies where the downstream PSD template exceeds this level. For all other frequencies, the PSD template remains unchanged. Note that this model is based on a smooth cutback mechanism, although practical ADSL modems may cut back their power in discrete steps ("staircase").

$$PSD_{max,dBm} = \begin{cases} -40dBm/Hz & (if \Delta_p < 0dB) \\ -40dBm/Hz - \frac{4}{3} \times \Delta_p & (if 0 \leq \Delta_p \leq 9dB) \\ -52dBm/Hz & (if \Delta_p > 9dB) \end{cases} \quad \text{where } \Delta_p = (P_{rec,dBm} - P_{thres,dBm})$$

Expression 7: Maximum PSD values of the transmitted downstream signal, as a function of the band-limited received power P_{rec} and a threshold level of $P_{thres,dBm} = -0,75$ dBm, and represents some average of the "staircase"

4.14 Transmitter signal model for "FDD ADSL over ISDN"

The PSD template for modelling "FDD ADSL over ISDN" (TS 101 388 [7] and ITU-T Recommendation G.992.1 [8]) transmit spectra is defined in terms of break frequencies, as summarized in tables 14 and 13.

- Table 13 is to be used for modelling "adjacent FDD modems", usually enhanced by echo cancellation for improving the separation between upstream and downstream signals. Because a guard band is not needed here, no sub-carrier is left unused.

- Table 14 is to be used for modelling "guard band FDD modems", usually enhanced by steep filtering for improving the separation between upstream and downstream signals. 7 sub-carriers are left unused to enable this guard band to be implemented.

The associated values are constructed with straight lines between these break frequencies, when plotted against a *logarithmic* frequency scale and a *linear* dBm scale. The frequency Δf in this table refers to the spacing of the DMT sub-carriers of ADSL. The source impedance equals $R_s = 100 \Omega$.

NOTE: These models do not apply to the associated ADSL2 (annex B) variant (ITU-T Recommendation G.992.3 [9]).

Table 13: PSD template values at break frequencies for modelling "FDD ADSL over ISDN", implemented as "adjacent FDD" (with echo cancelling)

Adjacent FDD (using echo cancellation)				
FDD ADSL over ISDN DMT carriers		Up [33:63]	FDD ADSL over ISDN DMT carriers	
f [Hz]		P [dBm/Hz]	Down [64:255]	
f [Hz]		P [dBm/Hz]	P [dBm/Hz]	
0		-90	0	
50		-90	53,5 $\times\Delta f$ ($\approx 230,72$ k)	
22,5 $\times\Delta f$ ($\approx 97,03$ k)		-85,3	63,0 $\times\Delta f$ ($\approx 271,79$ k)	
32,5 $\times\Delta f$ ($\approx 140,16$ k)		-38	63,5 $\times\Delta f$ ($\approx 273,84$ k)	
63,5 $\times\Delta f$ ($\approx 273,84$ k)		-38	256 $\times\Delta f$ ($= 1\,104$ k)	
67,5 $\times\Delta f$ ($\approx 291,09$ k)		-55	1,250 M	
74,5 $\times\Delta f$ ($\approx 321,28$ k)		-60	1,500 M	
80,5 $\times\Delta f$ ($\approx 347,16$ k)		-97,8	2,100 M	
686 k		-100	3,093 M	
1,411 M		-100	4,545 M	
1,630 M		-110	30 M	
5,275 M		-112		
30 M		-112		
$\Delta f = 4,3125$ kHz			$\Delta f = 4,3125$ kHz	

NOTE: This PSD has no guard band.

Table 14: PSD template values at break frequencies for modelling "FDD ADSL over ISDN", implemented as "guard band FDD" (with filtering)

Guard band FDD (using filters)				
FDD ADSL over ISDN DMT carriers		Up [33:56]	FDD ADSL over ISDN DMT carriers	
f [Hz]		P [dBm/Hz]	Down [64:255]	
f [Hz]		P [dBm/Hz]	P [dBm/Hz]	
0		-90	0	
50		-90	53,5 $\times\Delta f$ ($\approx 230,72$ k)	
22,5 $\times\Delta f$ ($\approx 97,03$ k)		-85,3	63,0 $\times\Delta f$ ($\approx 271,79$ k)	
32,5 $\times\Delta f$ ($\approx 140,16$ k)		-38	63,5 $\times\Delta f$ ($\approx 273,84$ k)	
56,5 $\times\Delta f$ ($\approx 243,66$ k)		-38	256 $\times\Delta f$ ($= 1\,104$ k)	
60,5 $\times\Delta f$ ($\approx 260,91$ k)		-55	1,250 M	
67,5 $\times\Delta f$ ($\approx 291,09$ k)		-60	1,500 M	
73,5 $\times\Delta f$ ($\approx 316,97$ k)		-97,8	2,100 M	
686 k		-100	3,093 M	
1,411 M		-100	4,545 M	
1,630 M		-110	30 M	
5,275 M		-112		
30 M		-112		
$\Delta f = 4,3125$ kHz			$\Delta f = 4,3125$ kHz	

NOTE: This PSD allocates 7 unused sub-carriers.

Power cut back (downstream only)

The transmitter signal model includes a mechanism to cut back the power for short loops, using the same mechanism as specified in expression 7, for modelling "EC ADSL over ISDN" transmitters.

4.15 Transmitter signal model for "ADSL2/J" (All Digital Mode, FDD, annex J)

The PSD template for modelling the "ADSL2/J" transmit spectrum is defined in terms of break frequencies, as summarized in table 15. The associated values are constructed with straight lines between these break frequencies, when plotted against a *logarithmic* frequency scale and a *linear* dBm scale. The frequency Δf in this table refers to the sub-carrier spacing of the DMT tones of ADSL. The source impedance equals 100 Ω .

**Table 15: PSD template values at break frequencies for modelling "ADSL2/J" -
The values for $f_1...f_4$ and $PSD_1...PSD_3$ are specified in table 16**

ADSL2/J DMT carriers	Up [1:k]	ADSL2/J DMT carriers	Down [64:255]
f [Hz]	P [dBm/Hz]	f [Hz]	P [dBm/Hz]
0	-50	0	-90
1,5 k	-50	53,5 $\times\Delta f$ ($\approx 230,72$ k)	-90
3 k	PSD_1	63,0 $\times\Delta f$ ($\approx 271,79$ k)	-52
$f_1 = k \times \Delta f$	PSD_1	63,5 $\times\Delta f$ ($\approx 273,84$ k)	-40
f_2	PSD_2	256,0 $\times\Delta f$ ($= 1104,00$ k)	-40
f_3	PSD_3	1,250 M	-45
f_4	-97,8	1,500 M	-70
686 k	-100	2,100 M	-90
1,411 M	-100	3,093 M	-90
1,630 M	-110	4,545 M	-112
5,275 M	-112	30 M	-112
30 M	-112		
$\Delta f = 4,3125$ kHz		$\Delta f = 4,3125$ kHz	

Table 16: Parameter values for parameters used in table 15

US mask number (M)	Tone range [1...k]	f_1 [kHz]	f_2 [kHz]	f_3 [kHz]	f_4 [kHz]	PSD_1 [dBm/Hz]	PSD_2 [dBm/Hz]	PSD_3 [dBm/Hz]
1	1...32	32 $\times\Delta f$ ($\approx 140,16$)	153,38	157,50	192,45	-38,0	-55,0	-60,0
2	1...36	36 $\times\Delta f$ ($\approx 157,41$)	171,39	176,46	208,13	-38,5	-55,5	-60,5
3	1...40	40 $\times\Delta f$ ($\approx 174,66$)	189,31	195,55	224,87	-39,0	-56,0	-61,0
4	1...44	44 $\times\Delta f$ ($\approx 191,91$)	207,16	214,87	242,51	-39,4	-56,4	-61,4
5	1...48	48 $\times\Delta f$ ($\approx 209,16$)	224,96	234,56	260,90	-39,8	-56,8	-61,8
6	1...52	52 $\times\Delta f$ ($\approx 226,41$)	242,70	254,84	280,25	-40,1	-57,1	-62,1
7	1...56	56 $\times\Delta f$ ($\approx 243,66$)	260,40	276,14	300,85	-40,4	-57,4	-62,4
8	1...60	60 $\times\Delta f$ ($\approx 260,91$)	278,05	299,30	323,55	-40,7	-57,7	-62,7
9	1...63	63 $\times\Delta f$ ($\approx 273,84$)	291,09	321,28	345,04	-41,0	-58,0	-63,0

Power back-off

NOTE: The specification of power back-off is left for further study.

4.16 Transmitter signal model for "ADSL2/M" (over POTS, FDD, annex M)

The PSD template for modelling the "ADSL2/M" transmit spectrum is defined in terms of break frequencies, as summarized in table 17 and 18. The associated values are constructed with straight lines between these break

frequencies, when plotted against a *logarithmic* frequency scale and a *linear* dBm scale. The frequency Δf in this table refers to the sub-carrier spacing of the DMT tones of ADSL. The source impedance equals 100 Ω .

Table 17: PSD template values at break frequencies for modelling "ADSL2/M" - The values for $f_1...f_4$ and $PSD_1...PSD_3$ are specified in table 18

ADSL2/M DMT carriers		ADSL2/M DMT carriers	
Up [7:k]		Down [64:255]	
f [Hz]	P [dBm/Hz]	f [Hz]	P [dBm/Hz]
0	-101	0	-90
3,99k	-101	53,5 $\times\Delta f$ ($\approx 230,72$ k)	-90
4 k	-96	63,0 $\times\Delta f$ ($\approx 271,79$ k)	-52
6,5 $\times\Delta f$ ($\approx 28,03$ k)	PSD_1	63,5 $\times\Delta f$ ($\approx 273,84$ k)	-40
$f_1 = k \times \Delta f$	PSD_1	256,0 $\times\Delta f$ ($= 1104,00$ k)	-40
f_2	PSD_2	1,250 M	-45
f_3	PSD_3	1,500 M	-70
f_4	-97,8	2,100 M	-90
686 k	-100	3,093 M	-90
1,411 M	-100	4,545 M	-112
1,630 M	-110	30 M	-112
5,275 M	-112		
30 M	-112		
$\Delta f = 4,3125$ kHz		$\Delta f = 4,3125$ kHz	

Table 18: Parameter values for parameters used in table 17

US mask number (M)	Tone range [7...k]	f_1 [kHz]	f_2 [kHz]	f_3 [kHz]	f_4 [kHz]	PSD_1 [dBm/Hz]	PSD_2 [dBm/Hz]	PSD_3 [dBm/Hz]
1	7...32	32 $\times\Delta f$ ($\approx 140,16$)	153,38	157,50	192,45	-38,0	-55,0	-60,0
2	7...36	36 $\times\Delta f$ ($\approx 157,41$)	171,39	176,46	208,13	-38,5	-55,5	-60,5
3	7...40	40 $\times\Delta f$ ($\approx 174,66$)	189,31	195,55	224,87	-39,0	-56,0	-61,0
4	7...44	44 $\times\Delta f$ ($\approx 191,91$)	207,16	214,87	242,51	-39,4	-56,4	-61,4
5	7...48	48 $\times\Delta f$ ($\approx 209,16$)	224,96	234,56	260,90	-39,8	-56,8	-61,8
6	7...52	52 $\times\Delta f$ ($\approx 226,41$)	242,70	254,84	280,25	-40,1	-57,1	-62,1
7	7...56	56 $\times\Delta f$ ($\approx 243,66$)	260,40	276,14	300,85	-40,4	-57,4	-62,4
8	7...60	60 $\times\Delta f$ ($\approx 260,91$)	278,05	299,30	323,55	-40,7	-57,7	-62,7
9	7...63	63 $\times\Delta f$ ($\approx 273,84$)	291,09	321,28	345,04	-41,0	-58,0	-63,0

Power back-off

NOTE: The specification of power back-off is left for further study.

4.17 Transmitter signal model for "VDSL"

VDSL is defined for a range of scenarios, each with its own template PSD. The ETSI VDSL standard (TS 101 388 [7]) has foreseen the various pairs of PSD templates for upstream and downstream transceivers, as summarized in tables 19 to 22.

The PSD template for modelling each of these "VDSL" transmit spectra, is defined in terms of break frequencies, as specified in tables 23 to 26 and in tables 27 to 30. The associated values are constructed with straight lines between these break frequencies, when plotted against a *logarithmic* frequency scale and a *linear* dBm scale. The source impedance is equal to the selected design impedance, and can be $R_V = 135 \Omega$ or $R_V = 100 \Omega$.

NOTE: The templates below do not take into account that additional PSD reduction mechanisms like pre-defined downstream PSD limitation or automatic upstream power back-off can be applied in a practical situation. For the downstream signals of FTTEx-VDSL, and for the downstream signals of FTTCab-VDSL M2 (variant A and B), the transmitter is not allowed to fill the complete PSD mask, because it violates the maximum transmit power allowed. The transmitter has then to reduce the PSD, until the power constraint is fulfilled. This reduction mechanism is not specified in the VDSL standard. The templates below are based on a specific modem power reduction method using the ceiling power cutback. The actual transmit PSD could therefore differ from one modem to the other.

Table 19: VDSL/Cab - ETSI main bandplan (also known as 997)

	up	down	comment
1	E1::P.M1.withoutUS0	E1::Pcab.M1.A	Main plan, non-boosted, DS above 1 104 kHz
2	E1::P.M1.withoutUS0	E1::Pcab.M1.B	Main plan, non-boosted, DS above 958 kHz
3	E1::P.M1.withUS0	E1::Pcab.M1.A	Main plan, non-boosted, DS above 1 104 kHz
4	E1::P.M1.withUS0	E1::Pcab.M1.B	Main plan, non-boosted, DS above 958 kHz
5	E1::P.M2.withoutUS0	E1::Pcab.M2.A	Main plan, boosted, DS above 1 104 kHz
6	E1::P.M2.withoutUS0	E1::Pcab.M2.B	Main plan, boosted, DS above 958 kHz
7	E1::P.M2.withUS0	E1::Pcab.M2.A	Main plan, boosted, DS above 1 104 kHz
8	E1::P.M2.withUS0	E1::Pcab.M2.B	Main plan, boosted, DS above 958 kHz

Table 20: VDSL/Ex - ETSI main bandplan (also known as 997)

	up	DS	comment
1	E1::P.M1.withoutUS0	E1::Pex.P1.M1	Main plan, non-boosted, DS above 251 kHz
2	E1::P.M1.withoutUS0	E1::Pex.P2.M1	Main plan, non-boosted, DS above 138 kHz
3	E1::P.M1.withUS0	E1::Pex.P1.M1	Main plan, non-boosted, DS above 251 kHz
4	E1::P.M1.withUS0	E1::Pex.P2.M1	Main plan, non-boosted, DS above 138 kHz
5	E1::P.M2.withoutUS0	E1::Pex.P1.M2	Main plan, boosted, DS above 251 kHz
6	E1::P.M2.withoutUS0	E1::Pex.P2.M2	Main plan, boosted, DS above 138 kHz
7	E1::P.M2.withUS0	E1::Pex.P1.M2	Main plan, boosted, DS above 251 kHz
8	E1::P.M2.withUS0	E1::Pex.P2.M2	Main plan, boosted, DS above 138 kHz

Table 21: VDSL/Cab - ETSI optional bandplan (also known as 998)

	up	DS	comment
1	E2::P.M1.withoutUS0	E2::Pcab.M1.A	Optional plan, non-boosted, DS above 1 104 kHz
2	E2::P.M1.withoutUS0	E2::Pcab.M1.B	Optional plan, non-boosted, DS above 958 kHz
3	E2::P.M1.withUS0	E2::Pcab.M1.A	Optional plan, non-boosted, DS above 1 104 kHz
4	E2::P.M1.withUS0	E2::Pcab.M1.B	Optional plan, non-boosted, DS above 958 kHz
5	E2::P.M2.withoutUS0	E2::Pcab.M2.A	Optional plan, boosted, DS above 1 104 kHz
6	E2::P.M2.withoutUS0	E2::Pcab.M2.B	Optional plan, boosted, DS above 958 kHz
7	E2::P.M2.withUS0	E2::Pcab.M2.A	Optional plan, boosted, DS above 1 104 kHz
8	E2::P.M2.withUS0	E2::Pcab.M2.B	Optional plan, boosted, DS above 958 kHz

Table 22: VDSL/Ex - ETSI optional bandplan (also known as 998)

	up	DS	comment
1	E2::P.M1.withoutUS0	E2::Pex.P1.M1	Optional plan, non-boosted, DS above 251 kHz
2	E2::P.M1.withoutUS0	E2::Pex.P2.M1	Optional plan, non-boosted, DS above 138 kHz
3	E2::P.M1.withUS0	E2::Pex.P1.M1	Optional plan, non-boosted, DS above 251 kHz
4	E2::P.M1.withUS0	E2::Pex.P2.M1	Optional plan, non-boosted, DS above 138 kHz
5	E2::P.M2.withoutUS0	E2::Pex.P1.M2	Optional plan, boosted, DS above 251 kHz
6	E2::P.M2.withoutUS0	E2::Pex.P2.M2	Optional plan, boosted, DS above 138 kHz
7	E2::P.M2.withUS0	E2::Pex.P1.M2	Optional plan, boosted, DS above 251 kHz
8	E2::P.M2.withUS0	E2::Pex.P2.M2	Optional plan, boosted, DS above 138 kHz

Power back-off

<FOR FURTHER STUDY>

4.17.1 Templates compliant with the ETSI main band plan

Table 23: Default US PSD templates

E1::P.M1		E1::P.M2	
Frequency (kHz)	Template (dBm/Hz)	Frequency (kHz)	Template (dBm/Hz)
With optional band			
0	-110	0	-110
4	-110	4	-110
25	-40	25	-40
138	-40	138	-40
307	-90	307	-90
482	-100	482	-100
Without optional band			
0	-110	0	-110
225	-110	225	-110
226	-100	226	-100
Common PSD			
2 825	-100	2 825	-100
3 000	-80	3 000	-80
3 001	-61	3 001	-54,8
5 099	-61	5 099	-57,1
5 100	-82	5 100	-82
5 274	-102	5 274	-102
5 275	-112	5 275	-112
6 875	-112	6 875	-112
6 876	-102	6 876	-102
7 050	-82	7 050	-82
7 051	-61	7 051	-58,5
11 999	-61	10 000	-60
12 000	-82	11 999	-60
12 175	-102	12 000	-82
12 176	-112	12 175	-102
30 000	-112	12 176	-112
		30 000	-112

Table 24: Default DS FTTCab PSD templates

E1::Pcab.M1		E1::Pcab.M2	
Frequency (kHz)	Template (dBm/Hz)	Frequency (kHz)	Template (dBm/Hz)
Variant A			
0	-110	0	-110
225	-110	225	-110
226	-100	226	-100
929	-100	929	-100
1 104	-80	1 104	-80
Variant B			
0	-110	0	-110
225	-110	225	-110
226	-100	226	-100
770	-100	770	-100
945	-80	945	-80
946	-78,3	946	-77,3
947,2	-74,8	947,2	-73,8
949	-72	949	-71
958	-67,1	958	-66,1
1 104	-61	1 104	-60
Common			
1 105	-61	1 105	-60
2 999	-61	1 394	-51,4
3 000	-82	2 999	-54,8
3 174	-102	3 000	-82
3 175	-110	3 174	-102
4 925	-110	3 175	-110
4 926	-102	4 925	-110
5 100	-82	4 926	-102
5 101	-61	5 100	-82
7 049	-61	5 101	-57,1
7 050	-82	7 049	-58,5
7 224	-102	7 050	-82
7 225	-112	7 224	-102
30 000	-112	7 225	-112
		30 000	-112

Table 25: Default DS FTTEx P1 PSD templates

E1::Pex.P1.M1		E1::Pex.P1.M2	
Frequency (kHz)	Template (dBm/Hz)	Frequency (kHz)	Template (dBm/Hz)
0	-97,5	0	-97,5
3,99	-97,5	3,99	-97,5
4	-90	4	-90
138	-90	138	-90
139	-61	139	-61
217	-61	217	-61
256	-46,4	251	-48,2
1 254	-46,4	1 303	-48,2
1 677	-61	1 394	-51,4
2 999	-61	2 999	-54,8
3 000	-82	3 000	-82
3 174	-102	3 174	-102
3 175	-110	3 175	-110
4 925	-110	4 925	-110
4 926	-102	4 926	-102
5 100	-82	5 100	-82
5 101	-61	5 101	-57,1
7 049	-61	7 049	-58,5
7 050	-82	7 050	-82
7 224	-102	7 224	-102
7 225	-112	7 225	-112
30 000	-112	30 000	-112

Table 26: Default DS FTTEx P2 PSD templates

E1::Pex.P2.M1		E1::Pex.P2.M2	
Frequency (kHz)	Template (dBm/Hz)	Frequency (kHz)	Template (dBm/Hz)
0	-97,5	0	-97,5
3,99	-97,5	3,99	-97,5
4	-90	4	-90
138	-90	138	-90
139	-46,9	139	-48,5
1 265	-46,9	1 314	-48,5
1 677	-61	1 394	-51,4
2 999	-61	2 999	-54,8
3 000	-82	3 000	-82
3 174	-102	3 174	-102
3 175	-110	3 175	-110
4 925	-110	4 925	-110
4 926	-102	4 926	-102
5 100	-82	5 100	-82
5 101	-61	5 101	-57,1
7 049	-61	7 049	-58,5
7 050	-82	7 050	-82
7 224	-102	7 224	-102
7 225	-112	7 225	-112
30 000	-112	30 000	-112

4.17.2 Templates compliant with the ETSI optional band plan

Table 27: Optional US PSD templates

E2::P.M1		E2::P.M2	
Frequency (kHz)	Template (dBm/Hz)	Frequency (kHz)	Template (dBm/Hz)
With optional band			
0	-110	0	-110
4	-110	4	-110
25	-40	25	-40
138	-40	138	-40
307	-90	307	-90
Without optional band			
0	-110	0	-110
225	-110	225	-110
226	-100	226	-100
Common PSD			
482	-100	482	-100
3 575	-100	3 575	-100
3 750	-80	3 750	-80
3 751	-61	3 751	-55,7
5 199	-61	5 199	-57,2
5 200	-82	5 200	-82
5 374	-102	5 374	-102
5 375	-112	5 375	-112
8 325	-112	8 325	-112
8 326	-102	8 326	-102
8 500	-82	8 500	-82
8 501	-61	8 501	-59,3
11 999	-61	10 000	-60
12 000	-82	11 999	-60
12 175	-102	12 000	-82
12 176	-112	12 175	-102
30 000	-112	12 176	-112
		30 000	-112

Table 28: Optional DS FTTCab PSD templates

E2::Pcab.M1		E2::Pcab.M2	
Frequency (kHz)	Template (dBm/Hz)	Frequency (kHz)	Template (dBm/Hz)
Variant A			
0	-110	0	-110
225	-110	225	-110
226	-100	226	-100
929	-100	929	-100
1 104	-80	1 104	-80
Variant B			
0	-110	0	-110
225	-110	225	-110
226	-100	226	-100
770	-100	770	-100
945	-80	945	-80
946	-78,3	946	-77,3
947,2	-74,8	947,2	-73,8
949	-72	949	-71
958	-67,1	958	-66,1
1 104	-61	1 104	-60
Common			
1 105	-61	1 105	-60
3 749	-61	1 295	-54,1
3 750	-82	2 603	-54,1
3 924	-102	3 749	-55,7
3 925	-110	3 750	-82
5 025	-110	3 924	-102
5 026	-102	3 925	-110
5 200	-82	5 025	-110
5 201	-61	5 026	-102
8 499	-61	5 200	-82
8 500	-82	5 201	-57,2
8 674	-102	8 499	-59,3
8 675	-112	8 500	-82
30 000	-112	8 674	-102
		8 675	-112
		30 000	-112

Table 29: Optional DS FTTE_x P1 PSD templates

E2::Pex.P1.M1		E2::Pex.P1.M2	
Frequency (kHz)	Template (dBm/Hz)	Frequency (kHz)	Template (dBm/Hz)
0	-97,5	0	-97,5
3,99	-97,5	3,99	-97,5
4	-90	4	-90
138	-90	138	-90
139	-61	139	-61
217	-61	217	-61
255	-46,8	248	-49,4
1 262	-46,8	1 336	-49,4
1 677	-61	1 394	-51,4
3 749	-61	3 749	-55,7
3 750	-82	3 750	-82
3 924	-102	3 924	-102
3 925	-110	3 925	-110
5 025	-110	5 025	-110
5 026	-102	5 026	-102
5 200	-82	5 200	-82
5 201	-61	5 201	-57,2
8 499	-61	8 499	-59,3
8 500	-82	8 500	-82
8 674	-102	8 674	-102
8 675	-112	8 675	-112
30 000	-112	30 000	-112

Table 30: Optional DS FTTE_x P2 PSD templates

E2::Pex.P2.M1		E2::Pex.P2.M2	
Frequency (kHz)	Template (dBm/Hz)	Frequency (kHz)	Template (dBm/Hz)
0	-97,5	0	-97,5
3,99	-97,5	3,99	-97,5
4	-90	4	-90
138	-90	138	-90
139	-47,2	139	-49,7
1 273	-47,2	1 346	-49,7
1 677	-61	1 394	-51,4
3 749	-61	3 749	-55,7
3 750	-82	3 750	-82
3 924	-102	3 924	-102
3 925	-110	3 925	-110
5 025	-110	5 025	-110
5 026	-102	5 026	-102
5 200	-82	5 200	-82
5 201	-61	5 201	-57,2
8 499	-61	8 499	-59,3
8 500	-82	8 500	-82
8 674	-102	8 674	-102
8 675	-112	8 675	-112
30 000	-112	30 000	-112

5 Generic receiver performance models for xDSL

A receiver performance model is capable of estimating up to what performance a data stream can be recovered from a noisy signal. In all cases it assumes that this recovery meets predefined quality criteria such as a maximum error better than $BER < 10^{-7}$ (Bit Error Ratio).

The word *performance* refers within this context to a variety of quantities, including noise margin, signal margin and maximum data rate. When the receiver is ideal (zero internal receiver noise, infinite echo cancellation, etc), the noise margin and signal margin become equal.

Performance models are implementation and line code specific. Performance modelling becomes more convenient when broken down into a combination of smaller sub models (see figure 1).

- A line code independent *input* (sub)model that evaluates the effective SNR from received signal, received noise, and various receiver imperfections. Details are described in clause 5.1.
- A line code dependent *detection* (sub)model that evaluates the performance (e.g. the noise margin at a specified bitrate) from the effective SNR. Details are described in clause 5.2.
- An (optional) *echo-coupling* (sub)model that evaluates what portion of the transmitted signal flows into the receiver. Details are described in clause 5.3.

The flow diagram in figure 1 represents an xDSL transceiver that is connected via a common wire pair to another transceiver (not shown). This wire pair transports the transmitted signal, received signal and received noise simultaneously.

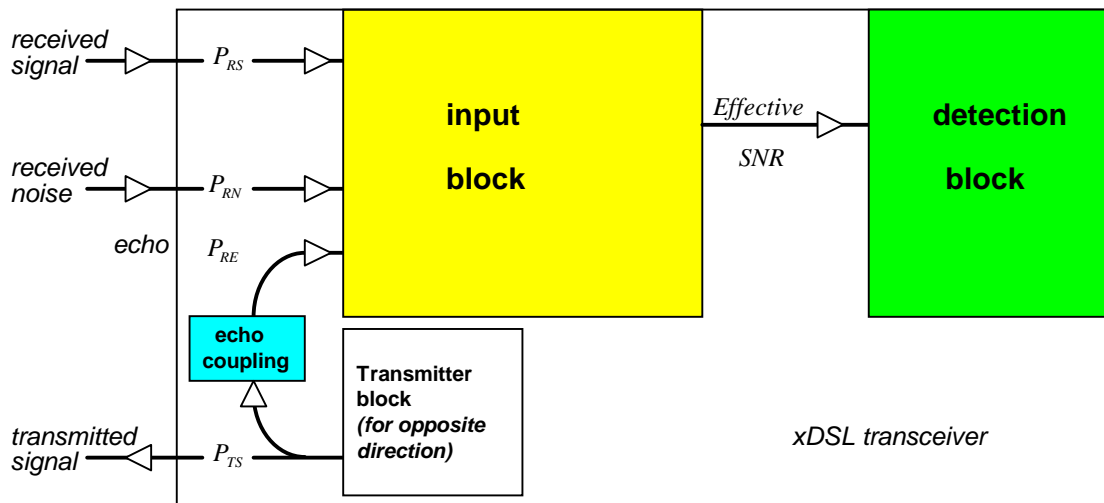

Figure 1: Flow diagram of a transceiver model, build up from individual sub models

The **input block** of the flow diagram in figure 1 requires values for *signal*, *noise* and *echo*. The flow diagram illustrates this for an xDSL transceiver that is connected via a common wire pair to another transceiver (not shown), which transports the following three flows simultaneously:

- The received *signal* power P_{RS} carries the data that is to be recovered. This signal originates from the transmitter at the other side of the wire pair, and its level is attenuated by cable loss.
- The received *noise* power P_{RN} is all that is received when the transmitters at both sides of the link under study are silent. The origin of this noise is mainly crosstalk from internal disturbers connected to the same cable (crosstalk noise), and partly from external disturbers (ingress noise).

- The received *echo* power P_{RE} is all that is received when the transmitter at the other end of the wire pair is silent, as well as all internal and external disturbers. It is a residue that will be received when a transmitter and a receiver are combined into a transceiver, and co-connected via a hybrid to the same wire pairs. No hybrid is perfect, so a portion (P_{RE}) of the transmitted signal (P_{TS}) will leak into the receiver and is identified as echo. Usually most of this is due to mismatch between the termination impedance, presented by the transceiver and the near end of the wire pair. Gauge changes along the wire pair also contribute echo.
- When the hybrid of that transceiver is unbalanced due to mismatched termination impedances (of the cable), then a portion (P_{RE}) of the transmitted signal (P_{TS}) will leak into the receiver and is identified as echo.

The input block in figure 1 evaluate a quantity called *effective SNR* (Signal to noise Ratio) that indicates to what degree the received signal is deteriorated by noise, residual echo and all kinds of implementation imperfections. Due to signal processing in the receiver, the *input* SNR (the ratio between signal power, and the power-sum of noise and echo) will change into the *effective* SNR at some virtual internal point at the receiver. The effective SNR can be better or worse than the input SNR. Receivers with build-in echo cancellation can take advantage of a-priori knowledge on the echo, and can suppress most of this echo to improve the effective SNR. On the other hand, all analogue receiver electronics produce shot noise and thermal noise, the A/D-converter produces quantization noise, and the equalization has its limitations as well. The combination of all these individual imperfections deteriorates the effective SNR. In principle all parameters of the effective SNR can be assumed as frequency dependent, but this dependency has been omitted here for reasons of simplicity. In addition, external change of signal and noise levels will modify the value of this effective SNR.

The **detection block** of the flow diagram in figure 1 requires this effective SNR to evaluate from that the performance as *margin* (such as noise margin, or signal margin). For many detection models, this margin is not provided by a closed expression, but by an equation from which this margin is to be solved. A simulation program may follow an iterative approach to solve this: controlling this margin in the input block so that the effective SNR changes and the equation in the detection block can be met.

In principle, the detection block is dedicated to line-code specific imperfections only, but may also include receiver imperfections that are not covered by the input block.

The **echo-coupling block** is optional, in case the input block does not deal with the related imperfections. Simple (first order) models for the input block cannot distinguish between receiver imperfection originated from echo and from other causes. When these simplified models are used, the echo-coupling block will not be required in the receiver performance model.

Clause 5 details (sub)models for the afore mentioned blocks in a receiver performance model, but is restricted to *generic* performance models only. Clause 6 is dedicated to implementation *specific* models by additionally assigning values to all parameters of a generic model.

5.1 Generic input models for effective SNR

An input (sub) model describes how to evaluate the effective SNR, as intermediate result (see figure 1), from various input quantities and imperfections. To simplify further analysis of performance quantities like *noise margin* and *signal margin*, the effective SNR is often expressed in its *offset format*, characterized by an additional parameter m . The associated expression is defined for each model individually.

By using this parameter m the external noise level can be increased (for noise margin calculations) or the external signal level can be decreased (for signal margin calculations). The convention is that when $m=1$ (equals zero dB) the effective *offset* SNR equals the effective SNR itself. When the value of parameter m increases, the effective offset SNR decreases.

5.1.1 First order input model

This input model is a simplified model that assumes that the SNR of the input signal is internally modified by internal receiver noise (P_{RNO}). Most imperfections of the receiver (such as front-end noise, imperfect echo suppression, imperfect equalization and quantization noise) are assumed to be concentrated in a single virtual internal noise source (P_{RNO}). Figure 2 shows the flow diagram of an xDSL transceiver model showing the elements of a first order input model for effective SNR evaluation, and how to incorporate it in the receiver performance model.

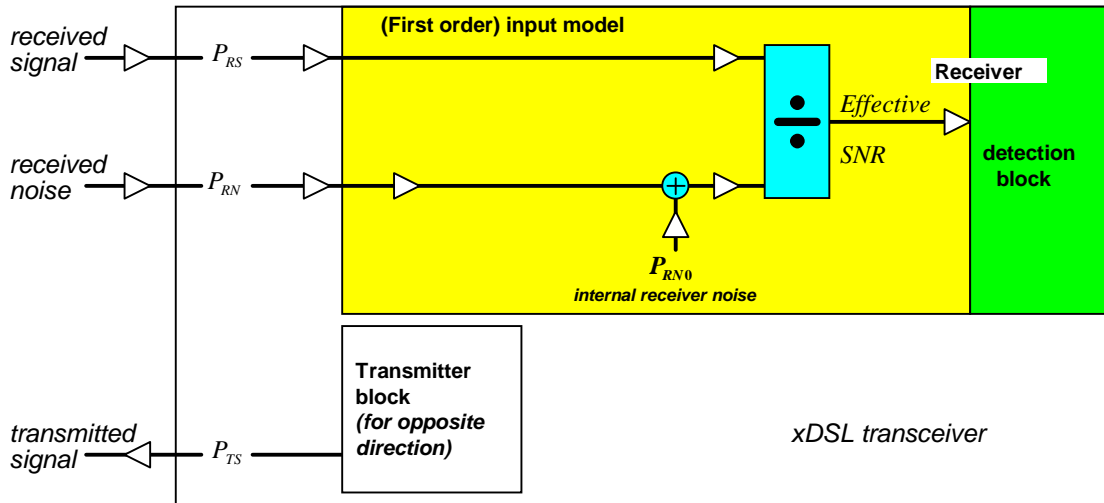

Figure 2: Flow diagram of a transceiver model that incorporates a linear first order input model for the determination of the effective SNR

Expression 8 summarizes how to evaluate the effective SNR for this model, in plain and in offset format. Table 31 summarizes the associated parameters.

Plain format:	$SNR(f)$	$= \frac{P_{RS}(f)}{P_{RN}(f) + P_{RN0}(f)}$
Noise offset format:	$SNR_{ofs,N}(m, f)$	$= \frac{P_{RS}(f)}{(P_{RN}(f) \times m) + P_{RN0}(f)}$
Signal offset format:	$SNR_{ofs,S}(m, f)$	$= \frac{P_{RS}(f) / m}{P_{RN}(f) + P_{RN0}(f)}$

Expression 8: Effective SNR, in various formats, when using the first order input model

Table 31: Associated parameters and quantities for a first order input model - All PSD levels may be frequency dependent. Constant $P_0=1\text{mW}$

Input quantities	linear	in dBm or dB	remarks
Received signal power	P_{RS}	$10 \times \log_{10}(P_{RS}/P_0)$	External signal
Received noise power (crosstalk)	P_{RN}	$10 \times \log_{10}(P_{RN}/P_0)$	External noise
Model Parameters			
Internal receiver noise power	P_{RN0}	$10 \times \log_{10}(P_{RN0}/P_0)$	Internal noise
Output quantities			
Signal to noise ratio (effective)	SNR	$10 \times \log_{10}(SNR)$	Frequency dependent

5.2 Generic detection models

This clause identifies several generic (sub) models for the detection block: one line code independent model derived from the Shannon capacity limit, and various line code dependent models dedicated to PAM, CAP/QAM or DMT line coding. Table 32 summarizes the naming convention for input and output quantities.

Table 32: Symbols used for input and output quantities of detection models

Input quantities	linear	in dB or dBm	remarks
Signal to Noise Ratio	SNR	$10 \times \log_{10}(SNR)$	Ratio of powers (frequency dependent)
Output quantities			
Noise margin	m_n	$10 \times \log_{10}(m_n)$	Ratio of noise powers
Signal margin	m_s	$10 \times \log_{10}(m_s)$	Ratio of signal powers

On input, the detection block requires an effective SNR, as provided by the input block. This SNR is a function of the frequency f . When the offset format is used for describing the SNR, it will also be a function of the offset parameter m . This offset format is specified individually for each model in clause 5.1.

On output, the detection block evaluates a signal margin m_n (or a noise margin m_s when more appropriate). This margin parameter is an important measure for the transport quality that is achieved under noisy conditions.

- The *Noise Margin* m_n indicates how much the received noise power can increase before the transmission becomes unreliable.
- The *Signal Margin* m_s indicates how much the received signal power can decrease before the transmission becomes unreliable.

Unless explicitly specified otherwise, the word *margin* refers in the present document to *noise margin*.

NOTE: From an xDSL deployment point of view, the analysis of noise margin is preferred over signal margin, since the (crosstalk) noise is the quantity that may increase when more systems are connected to the same cable. Many xDSL implementations, however, do report margin numbers that are not exactly equal to this noise margin, since the detection circuitry cannot make a distinction between external noise (due to crosstalk) and internal noise (due to imperfect electronics). These margins are often an estimate closer in value to the signal margin than to the noise margin.

5.2.1 Generic Shifted Shannon detection model

The calculation of the margin m using the generic Shifted Shannon detection model, is equivalent to solving the equation in expression 9. It has been derived from Shannon's capacity theorem, by reducing the effective SNR ("shifting" on a dB scale) by the SNR-gap G , to account for the imperfections of practical detectors. The associated parameters are summarized in table 33.

The effective SNR is to be evaluated by using one of the input models described in clause 5.1. Depending on what offset format is used for the SNR expression (see clause 5.1), the calculated margin m will represent the noise margin m_n or the signal margin m_s .

$$f_b = \int_{f_c - B/2}^{f_c + B/2} \log_2 \left(1 + \frac{SNR_{ofs}(m, f)}{\Gamma} \right) \times df$$

Expression 9: Equation of the Shifted Shannon detection model, for solving the margin m

Table 33: Parameters used for Shifted Shannon detection models

Model Parameters	linear	in dB	Remarks
SNR gap	G	$10 \times \log_{10}(G)$	
Line rate	f_b		= data rate (all payload bits that are transported in 1 sec) + overhead bitrate
Centre frequency	f_c		Centre value of the most relevant spectrum
Bandwidth	B		Width of most relevant spectrum
Margin	m	$10 \times \log_{10}(m)$	

The various parameters used within this generic detection model are summarized in table 33. The model can be made specific by assigning values to all these model parameters.

- The SNR-gap (G) is a performance parameter that indicates how close the detection approaches the Shannon capacity limit.
- The line rate (f_b) is usually higher than the data rate (0 % to 30 %) to transport overhead bits for error correction, signalling and framing.
- The bandwidth is a parameter that indicates what frequency range of the received spectrum is relevant for data transport. The model assumes that only frequencies within this range can pass the receive filters.

5.2.2 Generic PAM detection model

The calculation of the margin m using the generic PAM detection model is equivalent to solving the equation in expression 10. This model assumes ideal decision feedback equalizer (DFE) margin calculations. The associated parameters are summarized in table 34.

The effective SNR is to be evaluated by using one of the input models described in clause 5.1. Depending on what offset format is used for the SNR expression (see clause 5.1), the calculated margin m will represent the noise margin m_n or the signal margin m_s .

$$SNR_{req} = \Gamma \times (2^{2 \times b} - 1) = \exp \left(\frac{1}{f_s} \times \int_0^{f_s} \ln \left(1 + \sum_{n=N_L}^{N_H} SNR_{ofs}(m, f + n f_s) \right) \times df \right)$$

Expression 10: Equation of the PAM-detection model, for solving the margin m

The SNR gap G , being used in the above expression 10, is a combination of various effects. This G parameter is often split-up into the following three parts:

- A theoretical modulation gap G_{PAM} (in the order of 9,75 dB, at BER=10⁻⁷).
- A theoretical coding gain G_{coding} (usually in the order of 3 dB to 5 dB), to indicate how much additional improvement is achieved by the chosen coding mechanism.
- An empirical implementation loss G_{impl} (usually a few dB as well), indicating how much overall performance degradation is caused by implementation dependent imperfections (e.g. echo cancellation, analogue front end realization, equalization, etc), without identifying its true cause.

When G is split-up into the above three parts, its value shall be evaluated as follows:

$$\text{SNR gap (linear):} \quad G = G_{PAM} / G_{coding} \times G_{impl}$$

$$\text{SNR gap (in dB):} \quad G_{dB} = G_{PAM_dB} - G_{coding_dB} + G_{impl_dB}$$

The margin value, which can be either noise margin or signal margin, is not included in the SNR gap as it is contained in the offset SNR expression as described in clause 5.1.

Table 34: Parameters used for PAM detection models

Model Parameters	linear	in dB	remarks
SNR gap (effective)	G	$10 \times \log_{10}(G)$	$= SNR_{req} / (2^{2^b-1})$
SNR gap in parts:	G_{PAM}	$10 \times \log_{10}(G_{PAM})$	Modulation gap for PAM
	G_{coding}	$10 \times \log_{10}(G_{coding})$	Coding gain
	G_{impl}	$10 \times \log_{10}(G_{impl})$	Implementation loss
Required SNR	SNR_{req}	$10 \times \log_{10}(SNR_{req})$	$= G \times (2^{2^b-1})$
Line rate	f_b		= data rate (all payload bits that are transported in 1 sec) + overhead bitrate
Symbol rate	f_s		$= f_b / b$
Bits per symbol	b		$= f_b / f_s$ (can be non-integer)
Summation range	N_L, N_H		On default: $N_L = -2$ and $N_H = +1$
Margin	m	$10 \times \log_{10}(m)$	

The various parameters in table 34 used within this generic detection model have the following meaning:

- The SNR-gap (G) and required SNR (SNR_{req}) are equivalent parameters and can be converted from one to the other. The advantage of using G over SNR_{req} is that G can be defined with similar meaning for all theoretical models in the frequency domain (Shifted Shannon, CAP, PAM, and DMT). The advantage of using SNR_{req} over G is that this quantity is closer related to the SNR observed at the decision point of the detection circuitry.
- The line rate (f_b) is usually higher than the data rate (0 % to 30 %) to transport overhead bits for error correction, signalling and framing. The symbol rate is the line rate divided by the number of bits packed together in a single symbol.
- The summation range for n is from N_L to N_H , and this range has to be defined to make this generic model specific. Commonly used values for PAM, using over sampling, are $N_L = -2$ and $N_H = +1$. This corresponds to T/3-spaced equalization. Wider ranges are not excluded.

5.2.3 Generic CAP/QAM detection model

The calculation of the margin m using the generic CAP/QAM detection model is equivalent to solving the equation in expression 11. This model assumes ideal Decision Feedback Equalizer (DFE) margin calculations. The associated parameters are summarized in table 35.

The effective SNR is to be evaluated by using one of the input models described in clause 5.1. Depending on what offset format is used for the SNR expression (see clause 5.1), the calculated margin m will represent the noise margin m_n or the signal margin m_s .

$$SNR_{req} \equiv \Gamma \times (2^b - 1) = \exp \left(\frac{1}{f_s} \times \int_0^{f_s} \ln \left(1 + \sum_{n=N_L}^{N_H} SNR_{ofs}(m, f + nf_s) \right) \times df \right)$$

Expression 11: Equation of the CAP/QAM-detection model, for solving the margin m

The (effective) SNR gap G , being used in the above expression 11, is a combination of various effects. This has been explained in more detail for the PAM detection model. The theoretical modulation gap, identified as G_{CAP} for the CAP/QAM detection model, is in the order of 9,8 dB for BER= 10^{-7} .

The margin value, which can be either noise margin or signal margin, is not included in the SNR gap as it is contained in the offset SNR expression as described in clause 5.1.

Table 35: Parameters used for CAP/QAM detection models

Model Parameters	linear	in dB	remarks
SNR gap (effective)	G	$10 \times \log_{10}(G)$	$= SNR_{req} / (2^{b-1})$
SNR gap in parts:	G_{CAP}	$10 \times \log_{10}(G_{PAM})$	Modulation gap for CAP/QAM
	G_{coding}	$10 \times \log_{10}(G_{coding})$	Coding gain
	G_{impl}	$10 \times \log_{10}(G_{impl})$	Implementation loss
Required SNR	SNR_{req}	$10 \times \log_{10}(SNR_{req})$	$= G \times (2^{b-1})$
Line rate	f_b		= data rate (all payload bits that are transported in 1 sec) + overhead bitrate
Symbol rate	f_s		$= f_b / b$
Bits per symbol	b		$= f_b / f_s$ (can be non-integer)
Summation range	N_L, N_H		On default: $N_L=0$ and $N_H=+3$
Margin	m	$10 \times \log_{10}(m)$	

The various parameters in table 35 used within this generic detection model have the following meaning:

- The SNR-gap (G) and required SNR (SNR_{req}) are equivalent parameters and can be converted from one to the other. The advantage of using G over SNR_{req} is that G can be defined with similar meaning for all theoretical models in the frequency domain (Shannon, CAP, PAM, and DMT). The advantage of using SNR_{req} over G is that this quantity is closer related to the SNR observed at the decision point of the detection circuitry.
- The line rate is usually higher than the data rate (0 % to 30 %), to transport overhead bits for error correction, signalling and framing. The symbol rate is the line rate divided by the number of bits packed together in a single symbol.
- The summation range for n is from N_L to N_H . Commonly used values for CAP/QAM systems using over sampling are $N_L=0$ and $N_H=+3$. This holds when the carrier frequency positions the spectrum low in the frequency band (e.g. CAP-based HDSL). Other values may be more appropriated when the carrier frequency moves the spectrum to higher frequencies (e.g. CAP based VDSL).

5.2.4 Generic DMT detection model

The calculation of the margin m using the generic DMT detection model is equivalent to solving the equations in expression 12, for a given line rate f_b (or given *data* line rate f_{bd}). The associated parameters are summarized in table 36, and function *load* is specified by the chosen bit-loading algorithm. The effective SNR is to be evaluated by using one of the input models described in clause 5.1. Depending on what offset format $SNR_{ofs}(m, f)$ is used to express this effective SNR for margins other than $m=1$ (equals zero dB), the solved margin m will result in the noise margin m_n or the signal margin m_s .

$$\begin{array}{l}
 b_k = \log_2 \left(1 + \frac{SNR_{ofs}(m, f_k)}{\Gamma} \right) \quad [bit / tone / symbol] \\
 f_{bd} = f_{sd} \times b = f_{sd} \times \sum_{k \in tones} load(b_k) \quad [bit / s] \\
 f_b = f_{bd} + f_{bs} \quad [bit / s]
 \end{array}$$

NOTE: The words "tone" refers to "sub-carrier" but is preferred here to express dimensions like [bits/tone].

Expression 12: Equations of the DMT-detection model, for solving the margin m for a given *data* line rate f_{bd} , and a given *data* symbol rate f_{sd} - The rate f_{sd} excludes all DMT symbols dedicated to synchronization

Bit-loading algorithm

The DMT sub-carriers are all positioned (centred) at a multiple of the sub-carrier frequency spacing Δf , and each sub-carrier theoretically may carry any fragment of a symbol, while a symbol can carry many bits (typically a few hundred or more). The way this bit space (bits per tone per symbol) is used to load each sub-carrier with bits is implementation dependent.

Bit-loading algorithms commonly use masking. Masking means skipping carriers for loading when their bit space b_k is below some predefined minimum value b_{min} , and limiting the bit-loading to some pre-defined maximum when the bit space b_k exceeds some predefined maximum b_{max} . This masking process is summarized in expression 13.

$$\begin{array}{l}
 b_k < b_{min} \quad \Rightarrow \quad load(b_k) \equiv 0 \\
 b_{min} \leq b_k \leq b_{max} \quad \Rightarrow \quad load(b_k) \equiv b_k \\
 b_k > b_{max} \quad \Rightarrow \quad load(b_k) \equiv b_{max}
 \end{array}$$

Expression 13: The bit loading used in (fractional) bit-loading algorithms

When the data transport is operating on its limits (margin $m=1$, or zero dB), the following bit-loading algorithms may apply, in addition to masking:

- *Fractional bit-loading* (FBL): sometimes referred to as *water-filling* - is a pure theoretical approach enabling loading of any real number of bits per symbol in any sub-carrier k (including non-integer fractions). This maximizes the use of the available capacity, but is impractical to implement.
- *Truncated bit-loading* (TBL): is a more feasible algorithm in practice, and loads on each sub-carrier k a number of bits equal to the largest non-negative integer *below* the bit space b_k .
- *Rounded bit-loading* (RBL): is also feasible in practice, and loads each sub-carrier k with a number of bits equal to the nearest non-negative integer of bit space b_k .
- *Gain adjusted bit-loading* (GABL): is a sophisticated combination of rounded bit-loading and adjustment of powers to each of the sub-carriers, so that each individual bit space b_k approaches a rounded value (minimizes the loss of capacity), while the total transmit power is kept unchanged on average.

In various applications, it may be assumed that the capacity of well-designed *gain adjusted* bit-loading algorithms closely match those achieved by *fractional* bit-loading algorithm. For the sake of simplicity, and for making capacity calculations in the present document less implementation dependent, the fractional bit-loading algorithm with constraint number of bits per sub-carrier and symbol, as in expression 13, is used as default for DMT calculations in the present document, unless specified explicitly otherwise.

SNR-Gap

The (effective) SNR gap G , being used in expression 12, is a combination of various effects. This has been explained in more detail for the PAM detection model. The theoretical modulation gap, identified as G_{DMT} for the DMT detection model, is in the order of 9,75 dB for BER= 10^{-7} .

The margin value, which can be either noise margin or signal margin, is not included in the SNR gap as it is contained in the offset SNR expression as described in clause 5.1.

Associated parameters

Table 36: Parameters used for DMT detection models

Input quantities	linear	in dB	remarks
Signal to Noise Ratio (effective value)	SNR	$10 \times \log_{10}(SNR)$	Frequency dependent ratio of powers
Model Parameters	linear	in dB	remarks
SNR gap (effective)	G	$10 \times \log_{10}(G)$	$= SNR_{req} / (2^{2 \cdot b} - 1)$
SNR gap in parts:	G_{DMT}	$10 \times \log_{10}(G_{DMT})$	Modulation gap for DMT
	G_{coding}	$10 \times \log_{10}(G_{coding})$	Coding gain
	G_{impl}	$10 \times \log_{10}(G_{impl})$	Implementation loss
Symbol rate		f_s	Symbol rate, being the total number of <i>all</i> DMT symbols, transmitted in 1 s (Thus <i>data</i> symbols and <i>synch</i> symbols)
		f_{sd}	Symbol rate fragment, being the rate of <i>data</i> symbols only (without the overhead of <i>synch</i> symbols) that carry payloads bits
Line rate		f_b	Line rate, being the total number of <i>all</i> bits (for <i>data</i> , <i>synch</i> and other overhead) that is to be transported in 1 s
		f_{bd}	Line rate fragment, caused by the bits in <i>data</i> symbols only
		f_{bs}	Line rate fragment, caused by the bits in <i>synch</i> symbols only
Available set of sub-carriers		$\{k\}$	Can be a subset of all possible sub-carriers. (e.g. $k \in [7:255]$)
Centre frequency location of tone k ; $k \in \text{tones}$		f_k	$f_k = k \times \Delta f$ $\Delta f = 4,3125 \text{ kHz}$ in all current DMT systems
Bits per data symbol		$b = \sum b_k$	$b = f_{bd} / f_{sd}$ The bits of each data symbol are spread out over all used sub-carriers, in fragments of b_k
Bit-loading algorithm		FBL TBL RBL GABL	Can be one of: <ul style="list-style-type: none"> Fractional bit-loading (a.k.a. water filling) Truncated bit-loading Rounded bit-loading Gain adjusted bit-loading
Minimum bit loading		b_{min}	Minimum number of bits per sub-carrier and per data symbol
Maximum bit loading		b_{max}	Maximum number of bits per sub-carrier and per data symbol
Output quantities	linear	in dB	remarks
Noise margin	m_n	$10 \times \log_{10}(m_n)$	
Signal margin	m_s	$10 \times \log_{10}(m_s)$	

The various parameters in table 36, used within this generic detection model, have the following meaning:

- The SNR-gap (G) is a parameter that shows how far from the Shannon capacity limit a modem is performing at a certain bit error rate.
- The symbol rate f_s , in [baud] or [symbols/s], refers to *all* symbols being transmitted in one second. Most of these are so called *data* symbols, because they carry bits for data transport, but after sending many data symbols, an additional *synch* symbol may be transmitted to keep the DMT transmission synchronized. The bits in each symbol are spread out over all involved DMT sub-carriers. The symbol rate is the sum of two fragments:
 - The *data* symbol rate f_{sd} , referring only to the rate of *data* symbols.
 - The *synch* symbol rate f_{ss} , referring only to the rate of remaining *synch* symbols.

In ADSL, for example, one additional *synch* symbol is transmitted after sending 68 *data* symbols, and 4 000 *data* symbols are transmitted in one second.

In VDSL, for example, the *data* symbol rate and (total) symbol rate are equal as there is no extra synchronization symbol as in ADSL.

- The line rate f_b [bits/s] refers to *all* bits being transmitted over the line in one second, including *all* overhead bits. Examples of overhead bits are bits for synchronization, all types of coding, the embedded operation channel, etc.

Similar to the symbol rate, the line rate is the sum of two fragments:

- The *data* line rate f_{bd} , refers to all bits in *data* symbols only, and covers payload bits as well as all overhead bits in a *data* symbol.
- The *synch* line rate f_{bs} , refers to all bits in the remaining *synch* symbols, and can be considered as 100 % overhead for transporting payload bits.

The bits in each symbol are spread out over the involved sub-carriers.

- The data rate f_d , in [bits/s], refers to the rate of *payload* bits only (also known as net data bits) that are to be transported by the DMT system. This rate does not include any transmission overhead, and is therefore lower than the line rate. Performance requirements are usually specified for these rates only, as for example the ETSI standard for ADSL (TS 101 388 [7]).
- The available sub-carriers are specified by a list of integers, indicating what centre frequencies are allocated to individual sub-carriers. For instance in ADSL it can contain any of the sub-carriers from tone 7 to tone 255.
- The centre frequency of a sub-carrier k is $k \times \Delta f$, where Δf is the sub-carrier spacing.
- b_{\min} and b_{\max} are the minimum and maximum number of bits, respectively, used in the masking process of the bit loading.

5.3 Generic models for echo coupling

5.3.1 Linear echo coupling model

This model describes a property of linear hybrids in transceivers, and models what portion of the transmitted signal couples directly into the receiver. The hybrid is characterized by two parameters:

- R_V , representing the output impedance of the transceiver. Commonly used values are the design impedances of the modems under test, including 100 Ω for ADSL and 135 Ω for SDSL.
- Z_B , representing the termination impedance that causes the hybrid to be perfectly balanced. This means that when the hybrid is terminated with this "balance impedance", no echo will flow into the receiver. For well-designed hybrids, this balance impedance is a "best guess" approximation of the "average" impedance of cables being used.

Figure 3 shows an equivalent circuit diagram of the above hybrid, represented as a Wheatstone bridge. The associated transfer function $H_E(j\omega)$ expresses what portion of the transmit signal will appear as echo.

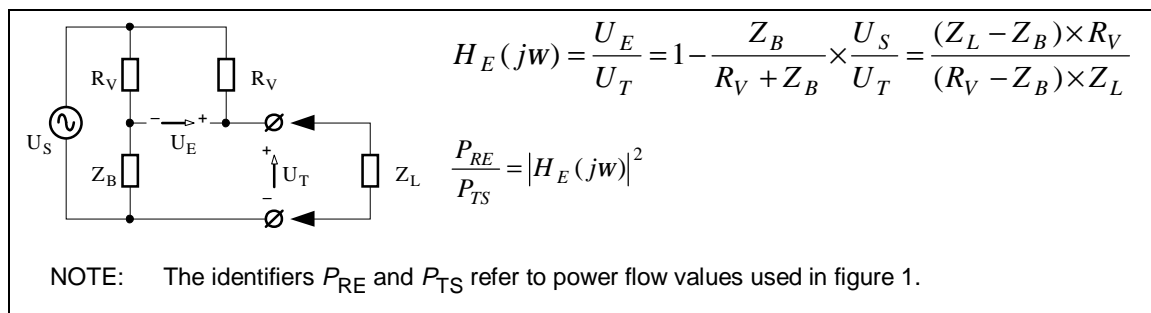

Figure 3: Flow diagram of the basic model for echo coupling

When using this basic model for echo coupling in a full simulation, value R_V can be made equal to the design impedance of the modem under test, and value Z_B can be made equal to the complex and frequency dependent input impedance of the cable, terminated at the other cable end with a load impedance equal to R_V . Values for R_V and Z_B are implementation specific.

6 Specific receiver performance models for xDSL

This clause defines parameter values for the generic performance models of clause 5, to provide implementation specific models for various xDSL modems.

6.1 Receiver performance model for "HDSL.2B1Q"

The reach predicted by this calculation model, under the stress conditions (loss, noise) of the associated ETSI HDSL specification (TS 101 135 [4]), is close to the reach required by ETSI specification (TS 101 135 [4]).

The receiver performance model for ETSI compliant HDSL.2B1Q is built-up from the following building blocks:

- A first order (linear) input model for the input block, specified in clause 5.1.1, that combines all imperfections (front-end noise, residual echo, equalization errors), in one virtual noise source.
- The generic PAM detection model, specified in clause 5.2.2.
- The parameter values specified in table 38.

The parameter values, used in the receiver performance model for ETSI compliant two-pair HDSL.2B1Q/2, are summarized in table 37. Parts of them are directly based on HDSL specifications. The remaining values are based on theory and assumptions.

Table 37: Values for the parameters used in the performance model, obtained from ETSI requirements for HDSL.2B1Q/2 [4]

Model Parameter		HDSL.2B1Q/2
SNR-Gap (effective)	G_{dB}	12,25 dB
SNR-Gap in parts	G_{PAM_dB}	9,75 dB
	G_{coding_dB}	0 dB
	G_{impl_dB}	2,5 dB
Receiver noise	P_{RNO_dB}	-140 dBm/Hz
Data rate	f_d	$2 \times 1\,024$ kb/s
Line rate	f_b	1 168 kb/s
bits per symbol	b	2
Summation bounds in the PAM model	N_H	+1
	N_L	-2
Derived Parameter		
Required SNR	SNR_{req}	$G \times (2^{2b} - 1)$
	SNR_{req_dB}	$\approx 24,0$ dB
Symbol rate	f_s	$f_b / b = 584$ kbaud
NOTE:	The receiver noise in this model has an unrealistic low level, but this is irrelevant for SpM studies in a mixed noise environment. As a result, this model will give too optimistic estimates of reachable distance in scenarios without any self crosstalk or any equivalent noise with similar bandwidth.	

6.2 Receiver performance model for "HDSL.CAP"

This calculation model is capable for predicting a performance that is benchmarked against the performance requirements of an ETSI compliant HDSL-CAP modem (TS 101 135 [4]). The reach predicted by this model, under the stress conditions (loss, noise) of the associated the TS 101 135 [4], is close to the reach required by TS 101 135 [4].

The receiver performance model for ETSI compliant HDSL-CAP is build-up from the following building blocks:

- A first order (linear) input model for the input block, specified in clause 5.1.1, that combines all imperfections (front-end noise, residual echo, equalization errors), in one virtual noise source.
- The generic CAP/QAM detection model, specified in clause 5.2.3.
- The parameter values specified in table 38.

The parameter values, used in the receiver performance model for ETSI compliant HDSL-CAP, are summarized in table 38. Parts of them are directly based on HDSL specifications. The remaining values are based on theory, followed by an iterative fit of the model to meet the ETSI reach requirements for HDSL-CAP under the associated stress conditions.

Various parameters are derived directly from the above-mentioned parameters. Their purpose is to simplify the required expression of the CAP/QAM-detection model used.

Table 38: Values for the parameters of the performance model, obtained from ETSI requirements for HDSL-CAP [4]

Model Parameter		HDSL.CAP/2	HDSL.CAP/1
SNR-Gap (effective)	G_{dB}	6,8 dB	6,8 dB
SNR-Gap in parts	G_{CAP_dB}	9,8 dB	9,8 dB
	G_{coding_dB}	5,0 dB	5,0 dB
	G_{impl_dB}	2,0 dB	2,0 dB
Receiver noise	P_{RNO_dB}	-105 dBm/Hz	-105 dBm/Hz
Data rate	f_d	2x1024 kb/s	1 x 2 048 kb/s
Line rate	f_b	1 168 kb/s	2 330 kb/s
Carrier frequency	f_c	138,30 kHz	226,33 kHz
bits per symbol	b	5	6
Summation bounds in the CAP/QAM model	N_H	+3	+3
	N_L	0	0
Derived Parameter			
Required SNR	SNR_{req}	$G \times (2^b - 1)$	$G \times (2^b - 1)$
	SNR_{req_dB}	$\approx 21,7$ dB	$\approx 24,8$ dB
Symbol rate	f_s	$f_b / b = 233,6$ kbaud	$f_b / b = 388,3$ kbaud

6.3 Receiver performance model for "SDSL"

This calculation model is capable of predicting a performance that is benchmarked against the performance requirements of an ETSI compliant SDSL modem (TS 101 524 [5]). The reach predicted by this model, under the stress conditions (loss, noise) of the associated the ETSI SDSL specification (TS 101 524 [5]) is close to the reach required by that ETSI specification. Deviations of predictions and requirements are less than 4,5 % in reach, and less than 125 m. The validity of the predicted performance holds for a wider range of stress conditions.

NOTE: These models are applicable to SDSL 16-UC-PAM at rates up to 2,312 Mb/s.

The receiver performance model for ETSI compliant SDSL is build-up from the following building blocks:

- A first order (linear) input model for the input block, specified in clause 5.1.1, that combines all imperfections (front-end noise, residual echo, equalization errors), in one virtual noise source (P_{RNO}).
- The generic PAM detection model, specified in clause 5.2.2.

- The parameter values specified in table 39.

The parameter values, used in the receiver performance model for ETSI compliant SDSL, are summarized in table 39. Some of these are directly based on SDSL specifications. The remaining values are based on theory.

Various parameters are derived from the above-mentioned parameters. Their purpose is to simplify the required expression of the PAM-detection model used.

Table 39: Values for the parameters of the performance model, obtained from ETSI requirements for SDSL [5]

Model parameter		SDSL model	
		≤ 256 kb/s	> 256 kb/s
SNR-Gap (effective)	G_{dB}	6,95 dB	6,25 dB
SNR-Gap in parts	G_{PAM_dB}	9,75 dB	9,75 dB
	G_{coding_dB}	4,4 dB	5,1 dB
	G_{impl_dB}	1,6 dB	1,6 dB
Receiver noise	P_{RNO_dB}	-140 dBm/Hz	
Data rate	f_d	192 ... 2 304 kb/s	
Line rate	f_b	$f_d + 8$ kb/s	
bits per symbol	b	3	
Summation bounds in PAM model	N_H	+1	
	N_L	-2	
Derived Parameter			
Required SNR	SNR_{req}	$G \times (2^{2b} - 1)$	
	SNR_{req_dB}	≈ 24,95 dB	≈ 24,25 dB
Symbol rate	f_s	$f_b / 3$	

6.4 Receiver performance model for "EC ADSL over POTS"

This calculation model is capable of predicting a performance that is benchmarked against the performance requirements of an ETSI compliant "EC ADSL over POTS" modem. The reach predicted by this model, under the stress conditions of the associated ETSI ADSL specification (TS 101 388 [7]), is close to the minimum reach required by that ETSI specification (TS 101 388 [7]). Deviations between the predicted reach and this "benchmark" reach are less than 100 m. The validity of the predicted performance holds for a wider range of stress conditions.

The receiver performance model for ETSI compliant "EC ADSL over POTS" is build-up from the following building blocks:

- A first order (linear) input model for the input block specified in clause 5.1.1, that combines all kinds of imperfections (front-end noise, residual echo and equalization errors), in one virtual noise source (P_{RNO}).
- The generic DMT detection model, specified in clause 5.2.4.
- The parameter values specified in table 40.

The parameter values, used in the receiver performance model for ETSI compliant "EC ADSL over POTS" modems, are summarized in table 40. Some of these are directly based on ADSL specifications. The remaining values are based on theory.

Table 40: Values for the performance parameters extracted from the ETSI performance requirements under ETSI stress conditions

Model parameter		DMT model		Remarks
		Upstream	Downstream	
SNR-Gap (effective)	G_{dB}	7,5 dB	7,5 dB	
SNR-Gap in parts	G_{DMT_dB} G_{Coding_dB} G_{impl_dB}	9,75 dB 4,25 dB 2,0 dB	9,75 dB 4,25 dB 2,0 dB	
Receiver noise	P_{RNO_dB}	-120 dBm/Hz	-135 dBm/Hz	
Symbol rate	f_s f_{sd}	69/68 × 4 000baud 4 000 baud	69/68 × 4 000 baud 4 000 baud	See clause 5.2.4
Data rate	f_d	32 ... 640 kb/s	32 ... 6 144 kb/s	These are minimum ranges only; wider ranges are usually supported
Line rate	f_{bd} f_b	$f_{bl} = f_d + 16 \times f_{sd}$ $f_{bh} = (f_d + 8 \times f_{sd}) \times 1,13$ $f_{bd} = \max(f_{bl}, f_{bh})$ $f_b = 69/68 \times f_{bd}$	$f_{bl} = f_d + 16 \times f_{sd}$ $f_{bh} = (f_d + 8 \times f_{sd}) \times 1,13$ $f_{bd} = \max(f_{bl}, f_{bh})$ $f_b = 69/68 \times f_{bd}$	See clause 5.2.4
Bits per symbol	b	f_{bd} / f_{sd}	f_{bd} / f_{sd}	
set of sub-carriers	$\{k\}$	$k \in [7:31]$	$k \in [7:63, 65:255]$	DMT tone $k = 64$ does not convey any bits because it is reserved as pilot tone.
Centre frequency location of tone k ; $k \in$ tones	f_k	$f_k = k \times \Delta f$ $\Delta f = 4,3125$ kHz	$f_k = k \times \Delta f$ $\Delta f = 4,3125$ kHz	
Bit-loading algorithm		FBL	FBL	See clause 5.2.4
Minimum bit-loading	b_{min}	2	2	Bits per tone per symbol
Maximum bit-loading	b_{max}	15	15	Bits per tone per symbol
NOTE 1: The relationship between line rate and data rate is a function of various modem settings, such as the use of trellis coding, interleaved mode, and framing parameters. The formulae in this table are a simplified model of this complex relationship.				
NOTE 2: The parameter values are for a modem in the interleaved mode.				

6.5 Receiver performance model for "FDD ADSL over POTS"

The receiver performance models for ETSI compliant "FDD ADSL over POTS" are build-up from the following building blocks:

- A first order (linear) input model for the input block specified in clause 5.1.1, that combines all kinds of imperfections (front-end noise, residual echo and equalization errors), in one virtual noise source (P_{RNO}).
- The generic DMT detection model, specified in clause 5.2.4.

This model is capable of evaluating the data rate (f_d), and uses the evaluation of the line rate (f_b) as intermediate step. In addition, the data rates (f_d) predicted by the model is to be limited to the maximum data rates (f_{d_max}) specified in table 41.

The parameter values, used in the receiver performance model for ETSI compliant "FDD ADSL over POTS" modems, are summarized in table 41. Some of these are directly based on ADSL specifications. The remaining values are extracted from ADSL performance requirements or based on theory.

Table 41: Values for the performance parameters of the ADSL receiver model

Model parameter		DMT model		Remarks
		Upstream	Downstream	
SNR-Gap (effective)	G_{dB}	9,0 dB	8,0 dB	
SNR-Gap in parts	G_{DMT_dB} G_{coding_dB} G_B G_{impl_dB}	9,75 dB 4,25 dB 3,5 dB	9,75 dB 4,25 dB 2,5 dB	
Receiver noise	P_{RN0_dB}	-120 dBm/Hz	-140 dBm/Hz	
Symbol rate	f_s f_{sd}	69/68 × 4 000baud 4 000 baud	69/68 × 4 000 baud 4 000 baud	See clause 5.2.4
Data rate	f_d f_{d_max}	32 kb/s ... f_{d_max} 800 kb/s (640 kb/s, see note 2)	32 kb/s ... f_{d_max} 8192 kb/s (6 144 kb/s, see note 2)	Limit data rate to these maxima, if model predicts higher rates
Line rate	f_{bd} f_b	$f_{bl} = f_d + 16 \times f_{sd}$ $f_{bh} = (f_d + 8 \times f_{sd}) \times 1,13$ $f_{bd} = \max(f_{bl}, f_{bh})$ $f_b = 69/68 \times f_{bd}$	$f_{bl} = f_d + 16 \times f_{sd}$ $f_{bh} = (f_d + 8 \times f_{sd}) \times 1,13$ $f_{bd} = \max(f_{bl}, f_{bh})$ $f_b = 69/68 \times f_{bd}$	See clause 5.2.4, and note 3
Bits per symbol	b	f_{bd} / f_{sd}	f_{bd} / f_{sd}	
Default set of sub-carriers, for use with "adjacent transmitter model"	{ k }	$k \in [7:31]$	$k \in [33:63, 65:255]$	DMT tone $k = 64$ does not convey any bits because it is reserved as pilot tone
Alternative set of sub-carriers, for use with "guard-band transmitter model"	{ k }	$k \in [7:31]$	$k \in [38:63, 65:255]$	DMT tone $k = 64$ does not convey any bits because it is reserved as pilot tone
Centre frequency location of sub-carrier k ; ($k \in$ sub-carriers)	f_k	$f_k = k \times \Delta f$ $\Delta f = 4,3125$ kHz	$f_k = k \times \Delta f$ $\Delta f = 4,3125$ kHz	
Bit-loading algorithm		FBL	FBL	See clause 5.3.4
Minimum bit-loading	b_{min}	1 (see note 1)	1 (see note 1)	Bits per tone per symbol
Maximum bit-loading	b_{max}	15 (see note 1, note 2, and max data rate f_{d_max})	15 (see note 1, note 2 and max data rate f_{d_max})	Data rate shall be limited to f_{d_max} if model predicts higher rates
<p>NOTE 1: The ADSL standard [8] specifies the bit-loading as integer values between 2 and 15, however the use of a model with "Fractional" bit-loading enables the use of non-integer values to account for other receiver properties as well. This enables the modelling of other receiver characteristics, as if the bit-loading caused them. Using a minimum bit-loading value of 1 instead of 2 is partially to account for absence of rounding in the FBL bit-loading and partially to account for increased bit-loading flexibility when modems operate with excess margin.</p> <p>In some cases it may be appropriate to use maximum upstream bit-loading lower than 15 in the models to account for imperfections commonly observed in real ADSL implementations.</p> <p>NOTE 2: The maximum data rate assumed for the first generation ADSL are 800 kb/s upstream and 8 192 kb/s downstream. In some cases these maximum values are limited to 640 kb/s upstream and 6 144 kb/s downstream. These limitations need to be considered when evaluating ADSL performance.</p> <p>NOTE 3: The correction factor 1.13 represents the Reed Solomon coding overhead, and is connected with the coding gain of 4,25 dB.</p> <p>NOTE 4: The relationship between line rate and data rate is a function of various modem settings, such as the use of trellis coding, interleaved mode, and framing parameters. The formulae in this table are a simplified model of this complex relationship.</p> <p>NOTE 5: The parameter values are for a modem in the interleaved mode.</p>				

6.6 Receiver performance model for "EC ADSL over ISDN"

This calculation model is capable of predicting a performance that is benchmarked against the performance requirements of an ETSI compliant "EC ADSL over ISDN" modem. The reach predicted by this model, under the stress conditions of the associated ETSI ADSL specification (TS 101 388 [7]), is close to the minimum reach required by that ETSI specification (TS 101 388 [7]). Deviations between the predicted reach and this "benchmark" reach are in most cases less than 80 m. The validity of the predicted performance holds for a wider range of stress conditions.

The receiver performance model for ETSI compliant "EC ADSL over ISDN" is build-up from the following building blocks:

- A first order (linear) input model for the input block specified in clause 5.1.1, that combines all kinds of imperfections (front-end noise, residual echo and equalization errors), in one virtual noise source (P_{RNO}).
- The generic DMT detection model, specified in clause 5.2.4.
- The parameter values specified in table 42.

The parameter values, used in the receiver performance model for ETSI compliant "EC ADSL over ISDN" modems, are summarized in table 42. Some of these are directly based on ADSL specifications. The remaining values are based on theory.

Table 42: Values for the performance parameters extracted from the ETSI performance requirements under ETSI stress conditions

Model parameter		DMT model		Remarks
		Upstream	Downstream	
SNR-Gap (effective)	G_{dB}	7,8 dB	7,5 dB	
SNR-Gap in parts	G_{DMT_dB} G_{coding_dB} G_{impl_dB}	9,75 dB 4,25 dB 2,3 dB	9,75 dB 4,25 dB 2,0 dB	
Receiver noise	P_{RNO_dB}	-120 dBm/Hz	-135 dBm/Hz	
Symbol rate	f_s f_{sd}	69/68 × 4 000 baud 4 000 baud	69/68 × 4 000 baud 4 000 baud	See clause 5.2.4
Data rate	f_d	32 ... 640 kb/s	32 ... 6 144 kb/s	These are minimum ranges only; wider ranges are usually supported
Line rate	f_{bd} f_b	$f_{bl} = f_d + 16 \times f_{sd}$ $f_{bh} = (f_d + 8 \times f_{sd}) \times 1,13$ $f_{bd} = \max(f_{bl}, f_{bh})$ $f_b = 69/68 \times f_{bd}$	$f_{bl} = f_d + 16 \times f_{sd}$ $f_{bh} = (f_d + 8 \times f_{sd}) \times 1,13$ $f_{bd} = \max(f_{bl}, f_{bh})$ $f_b = 69/68 \times f_{bd}$	See clause 5.2.4
Bits per symbol	b	f_{bd} / f_{sd}	f_{bd} / f_{sd}	
set of sub-carriers	$\{k\}$	$k \in [33:63]$	$k \in [33:95, 97:255]$ <i>Tone 96 = pilot tone</i>	<i>DMT tone $k = 96$ does not convey any bits because it is reserved as pilot tone.</i>
Centre frequency location of tone k ; $k \in$ tones	f_k	$f_k = k \times \Delta f$ $\Delta f = 4,3125$ kHz	$f_k = k \times \Delta f$ $\Delta f = 4,3125$ kHz	
Bit-loading algorithm		FBL	FBL	See clause 5.2.4
Minimum bit-loading	b_{min}	2	2	<i>Bits per tone per symbol</i>
Maximum bit-loading	b_{max}	15	15	<i>Bits per tone per symbol</i>
NOTE 1: The relationship between line rate and data rate is a function of various modem settings, such as the use of trellis coding, interleaved mode, and framing parameters. The formulae in this table are a simplified model of this complex relationship.				
NOTE 2: The parameter values are for a modem in the interleaved mode.				

6.7 Receiver performance model for "FDD ADSL over ISDN"

The downstream receiver performance model for ETSI compliant "FDD ADSL over ISDN" is build-up from the following building blocks:

- A first order (linear) input model for the input block specified in clause 5.1.1, that combines all kinds of imperfections (front-end noise, residual echo and equalization errors), in one virtual noise source (P_{RN0}).
- The generic DMT detection model, specified in clause 5.2.4.

This model is capable of evaluating the data rate (f_d), and uses the evaluation of the line rate (f_b) as intermediate step. In addition, the data rates (f_d) predicted by the model is to be limited to the maximum data rates (f_{d_max}) specified in table 43.

The parameter values, used in the receiver performance model for ETSI compliant "FDD ADSL over ISDN" modems, are summarized in table 43. Some of these are directly based on ADSL specifications. The remaining values are extracted from the ADSL performance requirements or based on theory.

Table 43: Values for the performance parameters of the ADSL receiver model

Model parameter		DMT model		Remarks
		Upstream	Downstream	
SNR-Gap (effective)	G_{dB}	8,0 dB	7,0 dB	
SNR-Gap in parts	G_{DMT_dB} G_{coding_dB} G_{impl_dB}	9,75 dB 4,25 dB 2,5 dB	9,75 dB 4,25 dB 1,5 dB	
Receiver noise	P_{RNO_dB}	-120 dBm/Hz	-140 dBm/Hz	
Symbol rate	f_s f_{sd}	69/68 × 4 000 baud 4 000 baud	69/68 × 4 000 baud 4 000 baud	See clause 5.2.4
Data rate	f_d f_{d_max}	32 kb/s ... f_{d_max} 800 kb/s (640 kb/s, see note 2)	32 kb/s ... f_{d_max} 8 192 kb/s (6 144 kb/s, see note 2)	Limit data rate to these maxima, if model predicts higher rates
Line rate	f_{bd} f_b	$f_{bl} = f_d + 16 \times f_{sd}$ $f_{bh} = (f_d + 8 \times f_{sd}) \times 1,13$ $f_{bd} = \max(f_{bl}, f_{bh})$ $f_b = 69/68 \times f_{bd}$	$f_{bl} = f_d + 16 \times f_{sd}$ $f_{bh} = (f_d + 8 \times f_{sd}) \times 1,13$ $f_{bd} = \max(f_{bl}, f_{bh})$ $f_b = 69/68 \times f_{bd}$	See clause 5.2.4 and note 3
Bits per symbol	b	f_{bd} / f_{sd}	f_{bd} / f_{sd}	
Default set of sub carriers, for use with "adjacent transmitter model"	{ k }	$k \in [33:63]$ see note 4	$k \in [64:95, 97:255]$ see note 4	DMT tone $k = 96$ does not convey any bits because it is reserved as pilot tone
Alternative set of sub carriers, for use with "guard band transmitter model"	{ k }	$k \in [33:56]$ see note 4	$k \in [64:95, 97:255]$ see note 4	DMT tone $k = 96$ does not convey any bits because it is reserved as pilot tone
Centre frequency location of sub-carrier k ; ($k \in$ sub-carrier)	f_k	$f_k = k \times \Delta f$ $\Delta f = 4,3125$ kHz	$f_k = k \times \Delta f$ $\Delta f = 4,3125$ kHz	
Bit-loading algorithm		FBL	FBL	See clause 5.2.4
Minimum bit-loading	b_{min}	1 (see note 1)	1 (see note 1)	Bits per tone per symbol
Maximum bit-loading	b_{max}	15 (see note 1, note 2, and max data rate f_{d_max})	15 (see note 1, note 2 and max data rate f_{d_max})	Data rate shall be limited to f_{d_max} if model predicts higher rates
<p>NOTE 1: The ADSL standard [8] specifies the bit-loading as integer values between 2 and 15, however the use of a model with "Fractional" bit-loading enables the use of non-integer values to account for other receiver properties as well. This enables the modelling of other receiver characteristics, as if the bit-loading caused them. Using a minimum bit-loading value of 1 instead of 2 is partially to account for absence of rounding in the FBL bit-loading and partially to account for increased bit-loading flexibility when modems operate with excess margin.</p> <p>In some cases it may be appropriate to use maximum upstream bit-loading lower than 15 in the models to account for imperfections commonly observed in real ADSL implementations.</p> <p>NOTE 2: The maximum data rate assumed for the first generation ADSL are 800 kb/s upstream and 8 192 kb/s downstream. In some cases these maximum values are limited to 640 kb/s upstream and 6 144 kb/s downstream. These limitations need to be considered when evaluating ADSL performance.</p> <p>NOTE 3: The correction factor 1.13 represents the Reed Solomon coding overhead, and is connected with the coding gain of 4,25 dB.</p> <p>NOTE 4: The available set of tones, according to the standard, is somewhat wider and ranges for upstream $k \in [33:64]$, and for downstream $k \in [60:95, 97:255]$. However this was not intended to be used in overlap.</p> <p>NOTE 5: The relationship between line rate and data rate is a function of various modem settings, such as the use of trellis coding, interleaved mode, and framing parameters. The formulae in this table are a simplified model of this complex relationship.</p> <p>NOTE 6: The parameter values are for a modem in the interleaved mode.</p>				

6.8 Receiver performance model for "VDSL"

NOTE: This model is left for further study.

7 Transmission and reflection models

7.1 Summary of test loop models

Over the years, a variety of two-port models have been extracted from cable measurements up to 30 MHz, and published in several documents. These models are so numerous due to the wide range of cables being used in different countries.

An example of a two-port models of a 100 Ω cable and of a 150 Ω cable can be found in the VDSL (TS 101 270-1 [10], annex A).

NOTE: Other examples of two-port cable models can be found in ETSI specifications for SDSL (TS 101 524 [5]) and ADSL (TS 101 388 [7]), however they are not defined up to the full 30 MHz band.

8 Crosstalk models

Crosstalk models account for the fact that the transmission is impaired by crosstalk originated from discrete disturbers distributed over the local loop wiring. In practice this is not restricted to a linear cable topology, since wires may fan out into different directions to connect for instance different customers to a central office.

This clause summarizes basic models for evaluating specific crosstalk characteristics, and topology models that uses a combination of these basic models for predicting how much noise is coupled into a wire pair within a specific scenario.

8.1 Basic models for crosstalk cumulation

These sub-models are applicable for representing a group of *co-located* disturbers by a single *equivalent* disturber, causing similar impairment to victim modems. When studying the noise in a specific wire pair, originating from several *co-located* disturbers connected to different wire pairs, then this noise depends on the mix of disturbers and to what wire pairs they are connected. When these wire pairs for (disturbing) modems are selected at random, then the generated crosstalk level in the wire pair being studied is also random in nature, since each wire pair couples at different ratio to that wire pair. However, from a statistical point of view this crosstalk noise cumulates in level when more co-located disturbers are involved. In addition, when the number of co-located disturbers increases, the spread in crosstalk noise level reduces.

A convenient approach to model this random noise level is to replace all individual disturbers by a single *equivalent* disturber, and to shape the level of that equivalent disturber in such a way that its crosstalk will not be exceeded in most of the cases. We are in general interested in a near worst case bound of the crosstalk level, and therefore a commonly used criterium is to define "most of the cases" as the 99 % limit. This is to approximate almost all cases, without being too pessimistic for the very last 1 % extreme cases.

This may explain why the cumulant is usually not a linear (weighed) sum of the individual disturbing powers. The obvious linear (weighed) sum of powers is appropriate only for the mean power level case.

A cumulation model is to account for the statistical distribution of all involved crosstalk coupling ratios when a well defined mix of disturbers is connected at random to a cable. On input, the cumulation building block requires the levels ($P_{d1} \dots P_{dN}$) of all involved individual disturbers that are co-located. On output, the cumulation building block evaluates the level of the equivalent disturbance ($P_{d,eq}$).

This clause provides expressions to model building blocks for crosstalk cumulation.

8.1.1 FSAN sum for crosstalk cumulation

The FSAN sum is generally used to model crosstalk cumulation, and is specified in expression 14. The (frequency dependent) power level of the equivalent disturbance, which combines M individual disturbers, is expressed below.

$$P_{d.eq}(f) = \left(P_{d1}(f)^{K_n} + P_{d2}(f)^{K_n} + P_{d3}(f)^{K_n} + \dots + P_{dM}(f)^{K_n} \right)^{1/K_n}, \text{ with } K_n = \frac{1}{0,6}$$

Expression 14: FSAN sum for cumulating the power levels of M individual disturbers into the power level of an equivalent disturber

K_n is assumed to be frequency independent. In the special case that all M disturbers generates equal power levels (P_d) at all frequencies of interest, the FSAN sum simplifies into $P_{d.eq}(f) = P_d(f) \times M^{1/K_n}$.

NOTE: For some cables used in the Netherlands, it has been observed that a slightly different value for K_n provides a better fit with measurements on these cables. For instance, values between 1/0,6 and 1/0,8 have been observed. For those cases in the Netherlands, these values for K_n may be more appropriate for use in expression 14.

The FSAN sum ignores differences in source impedances of different disturber types. For cumulating disturbance from sources with different impedances, their *available* power levels are to be combined according to the FSAN sum. This available power of a source is the power dissipated in a load resistance, equal to the source impedance.

8.2 Basic models for crosstalk coupling

These sub-models are applicable for evaluating how much noise a single disturber (or an equivalent disturber representing a group of co-located disturbers) will couple into a wire pair being studied.

The *equivalent* crosstalk coupling to a wire pair being studied is defined for the special case that all other wire pairs of the cable are connected to identical disturbers. It represents the ratio of the crosstalk level being observed in the wire pair being studied and the level of the associated equivalent disturber, as defined by the chosen cumulation model. The individual coupling between wire pairs fluctuate rapidly when the frequency changes, but these fluctuations are significantly lower for the equivalent coupling (especially when many wire pairs are involved).

The equivalent crosstalk coupling will be different for each wire pair, due to the spread in coupling ratios of individual wire pairs. When the wire pair under study is not specified, the worst case wire pair of the cable is commonly used for that. Such a choice, in combination with an adequate 99 % cumulation model, will enable near worst case studies of crosstalk noise levels that will not be exceeded in 99 % of the cases on a worst case wire pair of a cable.

This clause provides expressions to model the building blocks for equivalent crosstalk coupling.

8.2.1 Models for equivalent NEXT and FEXT

Expression set 15 specifies how to model the transfer functions of the equivalent NEXT and FEXT building blocks. The specification is based on the following constants, parameters and functions:

- Variable f identifies the frequency.
- Constant f_0 identifies a chosen reference frequency, commonly set to $f_0 = 1$ MHz.
- Variable L identifies the physical length of the cable between the two nodes in meters. Constant L_0 identifies a chosen reference length, commonly set to $L_0 = 1$ km.
- Function $s_T(f, L)$ represents the frequency and length dependent amplitude of the transmission function of the actual test loop, normalized to a reference impedance R_n . This value equals $s_T = |s_{21}|$, where s_{21} is the transmission s-parameter of the loop normalized to R_n . This R_n is commonly set to 135 Ω .
- Constant K_{xn} identifies an empirically obtained number that scales the NEXT transfer function $H_{next}(f, L)$.
- Constant K_{xf} identifies an empirically obtained number that scales the FEXT transfer function $H_{fext}(f, L)$.

$$H_{next}(f, L) = K_{xn} \times \left(\frac{f}{f_0} \right)^{0,75} \times \sqrt{1 - |s_T(f, L)|^4}$$

$$H_{fext}(f, L) = K_{xf} \times \left(\frac{f}{f_0} \right) \times \sqrt{L/L_0} \times |s_T(f, L)|$$

NOTE: Values for K_{xn} and K_{xf} are cable specific, and are to be specified for each scenario being studied. Commonly used values (in dB) for generic European studies, not dedicated to any particular cable or region, are: $K_{xn_dB} = -50$ dB and $K_{xf_dB} = -45$ dB for $f_0 = 1$ MHz and $L_0 = 1$ km.

Expression 15: Transfer functions of the basic models for NEXT and FEXT

8.3 Basic models for crosstalk injection

These sub-models are applicable to studies where the noise level has to be adjusted for impedance mismatch. When the impedance of the victim modem changes, the noise (and signal) observed by the receiver will change as well. To account for this effect, a crosstalk injection block can be included in a topology models.

The transfer function of the crosstalk injection block identified as H_{xi} , and is frequency and impedance dependent. Expression 16 illustrates how to use this transfer function for evaluating the power level P_{RN} from power level P_{XN} .

$$P_{RN} = P_{XN} \times |H_{xi}|^2$$

Expression 16: Evaluation of the receive noise level from the crosstalk noise level under matched conditions, by a transfer function of the noise injector

A transfer function that models the impact of impedance mismatch can be very complex, and therefore several simplified transfer functions are commonly used to approximate this effect. This clause summarizes a few of these approximations.

8.3.1 Forced noise injection

When crosstalk injection is modelled by means of *forced* noise injection, then all impedance and frequency dependency of noise injection is ignored. The associated transfer function is shown in expression 17.

$$H_{xi}(f) = 1$$

Expression 17: Transfer function for forced noise injection.

8.3.2 Current noise injection

When crosstalk injection is modelled by means of *current* noise injection, then it is assumed that the impedance dependency can be represented by the equivalent circuit diagram shown in figure 4. The associated transfer function is shown in expression 18.

- The *injection condition* holds when the performance is evaluated. Impedance Z_{LX} represents the cable with its terminating impedance at the other ends of the line. Z_{LX} is usually a frequency dependent and complex impedance.
- The *calibration condition* holds for the situation that noise has been evaluated. Z_{cal} should be a well-defined impedance. This can be a complex artificial impedance approximating Z_{LX} , or simply a fixed real impedance. In the special case that $Z_{cal} \equiv Z_{LX}$, the concept of "current injection" simplifies into "forced injection" as described in the previous clause.

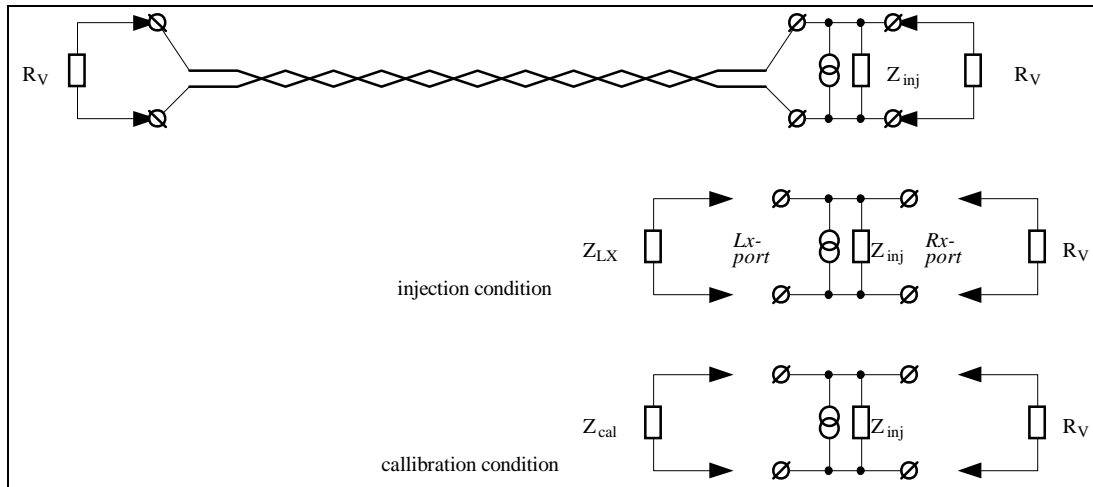

Figure 4: Current injection enables modelling of the impedance dependent behaviour of crosstalk noise levels

The transfer function $H_{xi}(f) = (U_i/U_c)$ between (a) the signal voltage U_i over impedance R_V during injection condition, and (b) U_c during calibration condition, equals:

$$H_{xi}(f, Z_{LX}) = \left(\frac{1/Z_{cal} + 1/Z_{inj} + 1/R_V}{1/Z_{LX} + 1/Z_{inj} + 1/R_V} \right)$$

Expression 18: Transfer function to model impedance dependency according to the current injection method

8.4 Overview of different network topologies

The results of spectral management studies are highly dependent on the chosen network topology, which is very country and location specific. The most simple topology models assume that all disturbers are co-located at only two locations; one at each end of a cable. This approximation is computational convenient but is generally inadequate to represent the real world. For example it will conceal effects due to fan out of the wires (relevant for short loops), and due to secondary NEXT.

More advanced topology models require a multi-node co-location approach. An example is the insertion of repeaters that introduces co-located disturbers in-between. Another example is deploying VDSL from the cabinet for the situation that all customers are distributed along the cable. It is recommended to use a multi-node approach, because this makes the simulation more realistic. A two-node approach implies that all NT disturbers are virtually co-located, and this is too pessimistic. This may cause pessimistic downstream results.

In practice topologies are not restricted to a linear cable topology, since wires may fan out into different directions to connect for instance different customers to a central office. This requires a branched multi-node approach. In the current version of the present document, only the most simple topology (with two nodes) has been elaborated, while the description of more advanced topology models is left for further study.

8.5 Topology crosstalk models for two-node co-location

The crosstalk models in this clause apply to scenarios in which it can be assumed that all customers are virtually co-located, and that they are all served from the central office. The result is that such a topology model requires only two nodes (one on the LT side, and another one on the "common" NT side). These nodes are interconnected by means of a multi wire pair cable.

Crosstalk models are built up from several building blocks, and the way these blocks are interconnected is defined by means of a topology diagram.

8.5.1 Basic diagram for two-node topologies

The basic flow diagram for describing a topology in which xDSL equipment is assumed to be co-located at two nodes (the two ends of a cable) is shown in figure 5 and 6. Upstream and downstream performance are evaluated separately. The approach of this diagram can be described in three distinct steps.

- The diagram combines for each node the output disturbance of individual disturbers (P_{d1}, P_{d2}, \dots) by modelling *crosstalk cumulation* as an isolated building block. By modelling crosstalk cumulation as an isolated building block, the cumulated disturbance can be thought as if it was virtually generated by a single equivalent disturber ($P_{d.eq}$). This has been indicated in figures 5 and 6 by a box drawn around the involved building blocks. Using the equivalent disturber concept as intermediate result yields an elegant concept to break down the complexity of a full noise scenario into smaller pieces.
- Next, the diagram evaluates what noise level (P_{XN}) is coupled into the wire pair of the victim modem being studied. Figures 5 and 6 illustrate what portion of the equivalent disturbance is coupled into that wire pair by using models for *NEXT* and *FEXT*. On top of this, background noise (P_{bn}) can be added. This can be used to represent all unidentified noise sources, line shared noise (from POTS/ISDN to ADSL), or anything else not incorporated in the NEXT and FEXT coupling models. Since it is a generic diagram, the power level of this background noise level is left undefined here, but commonly used values are zero, or levels as low as $P_{bn} = -140$ dBm/Hz.
- When all building blocks are modelled for the same impedance as implemented in the modem under study, the noise level (P_{RN}) received by the modem under test equals the level derived so far (P_{XN}). In practice, these models are normalized at some chosen reference impedance R_n , and this R_n may be different from the impedance implemented in the modem under study (targeted at its design impedance R_v). This "mismatch" will cause a change in the level of the disturbance, and this effect is modelled by the noise injection building block.

The transfer functions H_{next} and H_{fext} of the building blocks in figures 5 and 6 for NEXT and FEXT are linear and frequency dependent. The model for the topology assumes that all disturbers are uncorrelated, which causes that the crosstalk power P_{XN} behind the summation block is the sum of all individual powers. This transfer functions are specified in expression 19.

$$\begin{aligned}
 P_{XN,NT} &= P_{d.eq,NT} \times |H_{next}|^2 + P_{d.eq,LT} \times |H_{fext}|^2 + P_{bn,NT} \\
 P_{XN,LT} &= P_{d.eq,LT} \times |H_{next}|^2 + P_{d.eq,NT} \times |H_{fext}|^2 + P_{bn,LT}
 \end{aligned}$$

Expression 19: Evaluation of the crosstalk power levels, that flow into the noise injection blocks of the two-node topology models in figures 5 and 6

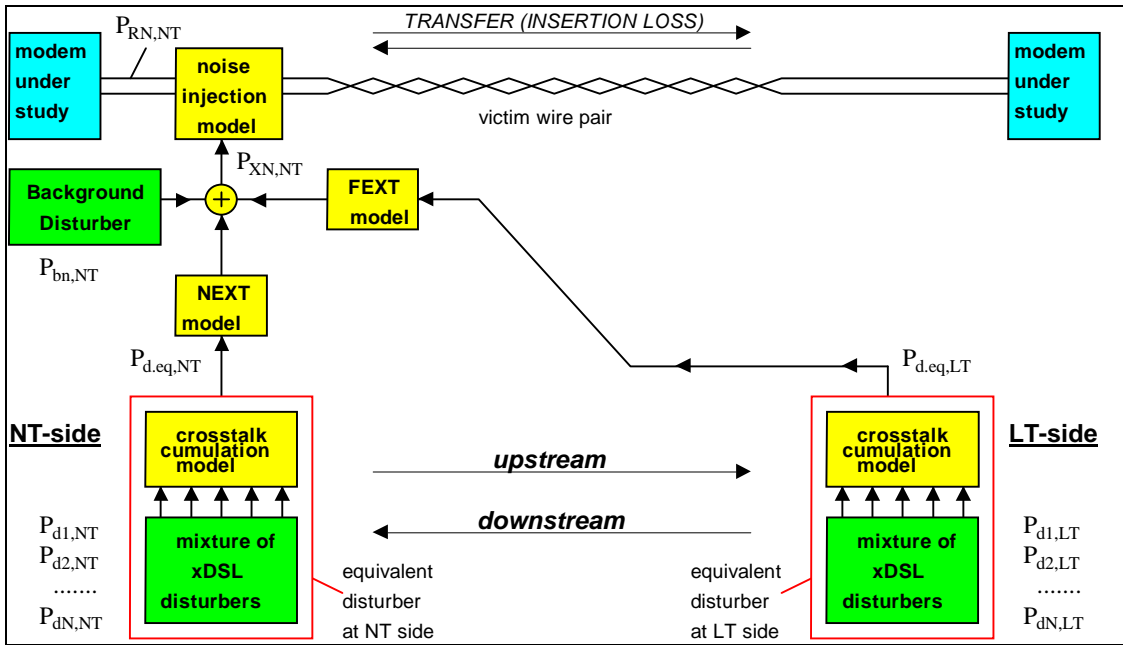

Figure 5: Flow diagram of the basic model for two-node topologies, for evaluating downstream performance

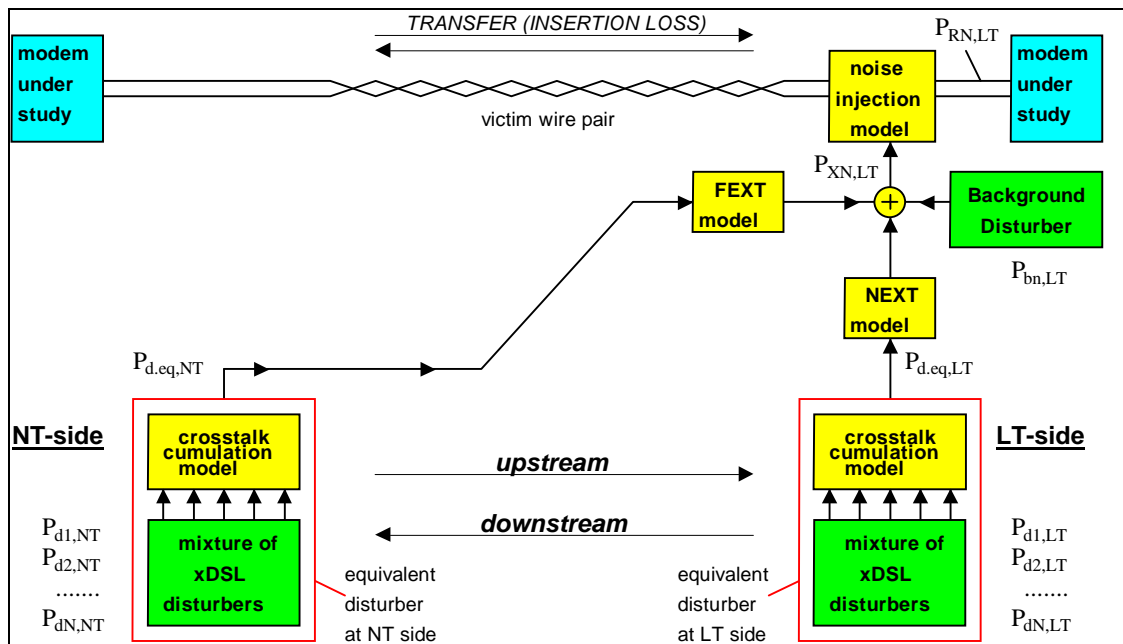

Figure 6: Flow diagram of the basic model for two-node topologies, for evaluating upstream performance

8.6 Topology crosstalk model for multi-node co-location

<for further study>

9 Examples of evaluating various scenarios

This clause summarizes examples to show how the models in the present document can be used to perform spectral management studies.

9.1 European Spectral Platform 2004 (ESP/2004)

In 2004 several European operators created a simulation platform to support spectral management studies on e-SDSL and ADL-64. This platform comprises of several (theoretical) scenarios to cover a wide range of situations being identified in European access networks. Each scenario is a compromise between computational convenience and computational complexity of real access networks. Nevertheless, the calculated performances of xDSL systems operating under these theoretical scenarios are assumed to be indicative for the minimum performance of these systems in various European situations.

The scenarios are a combination of a technology mix (to create a noise environment), system models, topology models and loop models.

9.1.1 Technology mixtures within ESP/2004

A distinct number of technology mixtures have been identified to enable a reasonable representation of scenarios that are being deployed in various European Networks. Their names are specified in table 44.

Table 44: Naming convention of used mixtures

Name	Description of the mix
	<i>High penetration mixtures</i>
HP/M	Mix includes both ADSL FDD flavours, SDSL, VDSL, HDSL.CAP/2 and HDSL.2B1Q/2
HP/R	Mix includes all four ADSL (FDD and EC) flavors, SDSL, VDSL and HDSL.CAP/2
	<i>Medium penetration mixtures</i>
MP/M	Mix includes both ADSL FDD flavours, SDSL, VDSL and HDSL.2B1Q/2
MP/P	Mix includes ADSL over POTS FDD, SDSL, VDSL and HDSL.2B1Q/2
MP/I	Mix includes ADSL over ISDN FDD, SDSL, VDSL and HDSL.2B1Q/2

The number of systems of each technology to be considered in each scenario is specified in table 45.

- For each *reference* scenario, the associated reference mix is specified in the columns labelled as "ref".
- For each *modified* scenario, the associated modified mix is specified in the columns labelled as "mod". The number of wire pairs occupied by the broadband systems remains the same as for the reference scenario.

By comparing the change in performance between both scenarios, the impact of replacing some "legacy" systems by systems of the new technology can be visualized. This concept is referred to as the "reference method".

NOTE: The victim system shall not be considered among the disturbers, i.e. it shall be subtracted from the total number of disturbing systems. For two-pairs HDSL systems, only one pair shall be considered as victim, whereas the other one shall be kept among the disturbers.

Table 45: Reference mixtures and modified mixtures with the new technology for the five scenarios

System	Mix	HP/M		HP/R		MP/M		MP/P		MP/I	
		Ref.	Mod.	Ref.	Mod.	Ref.	Mod.	Ref.	Mod.	Ref.	Mod.
SDSL 1024 kb/s		5	5	16	16	4	4	4	4	4	4
SDSL 2048 kb/s		10	10	16	16	5	5	5	5	5	5
HDSL 2B1Q/2		3x2	2x2	-	-	1x2	0x2	1x2	1x2	1x2	1x2
HDSL CAP/2		2x2	2x2	3x2	3x2	-	-	-	-	-	-
ADSL over POTS FDD		75	68	63	55	18	16	25	20	-	-
ADSL over ISDN FDD		25	22	96	84	7	6	-	-	25	20
ADSL over POTS EC		-	-	21	19	-	-	-	-	-	-
ADSL over ISDN EC		-	-	32	29	-	-	-	-	-	-
VDSL (FTTEx)		12 ¹⁾	12 ¹⁾	25 ²⁾	25 ²⁾	5 ¹⁾	5 ¹⁾	5 ¹⁾	5 ¹⁾	5 ³⁾	5 ³⁾
New system under study		0	12	0	25	0	5	0	5	0	5
ISDN.2B1Q (alone)		50	53	97	103	14	15	14	14	0	0
ISDN.2B1Q/filtered ⁶⁾		25 ⁴⁾	22	53 ⁴⁾	48 ⁴⁾	7 ⁴⁾	6 ⁴⁾	0	0	0	0
ISDN.MMS43 (alone)		0	0	0	0	0	0	0	0	14	19
ISDN.MMS43/filtered ⁶⁾		0	0	0	0	0	0	0	0	30 ⁵⁾	30 ⁵⁾
Pairs in total for BB		137	137	275	275	41	41	41	41	41	41
Pairs in total for BB and ISDN		187	190	372	378	55	56	55	55	55	60

NOTE 1: VDSL (FTTEx) P2 M2 with US0, ETSI main plan (997) or optional regional band plan (998).
NOTE 2: VDSL (FTTEx) P2 M2 with US0, ETSI main plan (997) only.
NOTE 3: VDSL (FTTEx) P1 M1 without US0, ETSI main plan (998) only.
NOTE 4: These ISDN/2B1Q systems share the same pair with ADSL over ISDN systems.
NOTE 5: These ISDN/MMS43 systems share the same pair with ADSL or VDSL over ISDN systems.
NOTE 6: In case the victim modem shares the line with ISDN, reduce the number of filtered ISDN disturbers by one, and add a "Line shared ISDN" model to the line of that victim modem.

NOTE 1: When VDSL is considered as disturbing system for the other systems it is not necessary to specify its band plan. When making simulations on VDSL performance instead, a homogeneous VDSL environment and the band plan indicated in the explanations of table 45 should be considered.

NOTE 2: The modified mixtures depend on the type of system under study. In this example the modified mixtures were determined for studies of ADL-64 and E-SDSL.

9.1.2 System models within ESP/2004

Table 46 specifies transmitter signal models for each system being part of the mix. Power back-off or power cut-back shall be taken into account for all the systems for which it is mandatory in the relevant specification. Concerning VDSL UPBO, use the reference PSD for Noise D (see TS 101 270-1 [10]) in high penetration scenarios (using HP/M and HP/R) and the one for Noise E in medium penetration scenarios (using MP/P, MP/I and MP/M).

Table 47 specifies receiver performance models for each system being part of the mix.

Table 46: Transmitter signal models

Name	Transmitter signal model
SDSL 1024 kb/s	SDSL transmitter model, as specified in clause 4.10 for 1 024 kb/s
SDSL 2048 kb/s	SDSL transmitter model, as specified in clause 4.10 for 2 048 kb/s
HDSL 2B1Q/2	HDSL transmitter model, as specified in clause 4.8 (use " default" model)
HDSL CAP/2	HDSL transmitter model, as specified in clause 4.9
ADSL over POTS FDD	ADSL transmitter model, as specified in clause 4.12 (<i>see note</i>)
ADSL over ISDN FDD	ADSL transmitter model, as specified in clause 4.14 (<i>see note</i>)
ADSL over POTS EC	ADSL transmitter model, as specified in clause 4.11
ADSL over ISDN EC	ADSL transmitter model, as specified in clause 4.13
VDSL (FTTEx)	VDSL transmitter model, as specified in clause 4.17
ISDN.2B1Q - alone	ISDN transmitter models, as specified in clause 4.2
ISDN.2B1Q/filtered	ISDN transmitter models, as specified in clause 4.3
ISDN.2B1Q - same pair	ISDN transmitter models, as specified in clause 4.4
ISDN.MMS43 - alone	ISDN transmitter models, as specified in clause 4.5
ISDN.MMS43/filtered	ISDN transmitter models, as specified in clause 4.6
ISDN.MMS43 - same pair	ISDN transmitter models, as specified in clause 4.4
NOTE:	Use the ADSL adjacent FDD template when ADSL is considered a disturber (in the noise), but use the ADSL guardband FDD template when ADSL is considered a victim.

Table 47: Receiver performance models

Name	Receiver performance model
SDSL	SDSL receiver model, as specified in clause 6.3
HDSL 2B1Q/2	HDSL receiver model, as specified in clause 6.1
HDSL CAP/2	HDSL receiver model, as specified in clause 6.2
ADSL over POTS FDD	ADSL receiver model, as specified in clause 6.5
ADSL over ISDN FDD	ADSL receiver model, as specified in clause 6.7
ADSL over POTS EC	ADSL receiver model, as specified in clause 6.4
ADSL over ISDN EC	ADSL receiver model, as specified in clause 6.6
VDSL (FTTEx)	<i>See note</i>
ISDN.2B1Q	<i>See note</i>
ISDN.MMS43	<i>See note</i>
NOTE:	The evaluation of the performance of this victim system is no part of ESP/2004; only broadband systems were investigated as victim system.

9.1.3 Topology models within ESP/2004

The scenario assumes that an uninterrupted homogeneous cable, without branches, interconnects the victim system under study. In addition, it assumes that the network topology can be represented by a simple (point-to-point) two-node topology model (see clause 8.5).

This is of course an over-simplification of real access networks, and therefore the way systems are disturbing each other is refined (a) according to the way NT systems are distributed along the cable, and (b) to what distance NT systems are separated from their LT counterpart.

Refinements of disturbance

For the first refinement, two different topologies are defined:

- ***Distributed topology***. Here it is assumed that the NT ports of a cable (or bundle or binder group) are distributed along the loop, and that a single cable is capable of providing access to customers at both near and far distances from the exchange.
- ***Virtually co-located topology***. Here it is assumed that the NT ports of a cable (or bundle or binder group) are virtually co-located, and that a single cable can only provide access to near locations or to far locations. Different cables are then needed to connect customers at both locations.

In either case, the LT disturbers are co-located with the LT victim. To compensate for the fact that some NT disturbers are not always at the same location as the NT victim system, the crosstalk of these disturbers is attenuated first.

Attenuated crosstalk means within this context the following: Assume that no disturber resides beyond the victim NT. If L is the distance between an investigated NT victim and a group of co-located NT disturbers, then calculate the crosstalk of these disturbers (NEXT & FEXT) at the location of these disturbers as if no other disturber does exist. In the following step, attenuate this noise level by the loss of a loop with length L . Repeat this for each group of co-located NT disturbers, and subsequently add the powers of all these crosstalk components to evaluate the crosstalk level at the location of the victims.

For the second refinement, the reach limits of the involved systems are accounting for the disturbance of such a system. This means that a system will not be deployed beyond its reach limits, and that the composition of the disturber mix changes when the loop length exceeds certain reach boundaries.

To simplify this refinement, only five reach boundaries are distinguished, and the involved systems are all classified according to these boundaries. This is summarized in table 48, and illustrated in figure 7.

Table 48: System classification according to the boundaries in figure 7

System class	System examples	Deployment practice
1	VDSL	VDSL will not be deployed beyond area 1 limit.
2	SDSL, 2 048 kb/s	2 048 kb/s SDSL will not be deployed beyond area 2 limits.
3	HDSL/2	Two-pair HDSL will not be deployed beyond area 3 limits, (except for "virtually co-located topologies" where the use of a regenerator is assumed to extend the reach).
4	SDSL, 1 024 kb/s	1 024 kb/s SDSL will not be deployed beyond area 4 limits. (except for "virtually co-located topologies" where the use of a regenerator is assumed to extend the reach).
5	ADSL ISDN (SDSL, 512 kb/s)	All these systems in the mix will be deployment up to area 5. (except for the "distributed topologies", that do not include 512 kb/s SDSL systems).

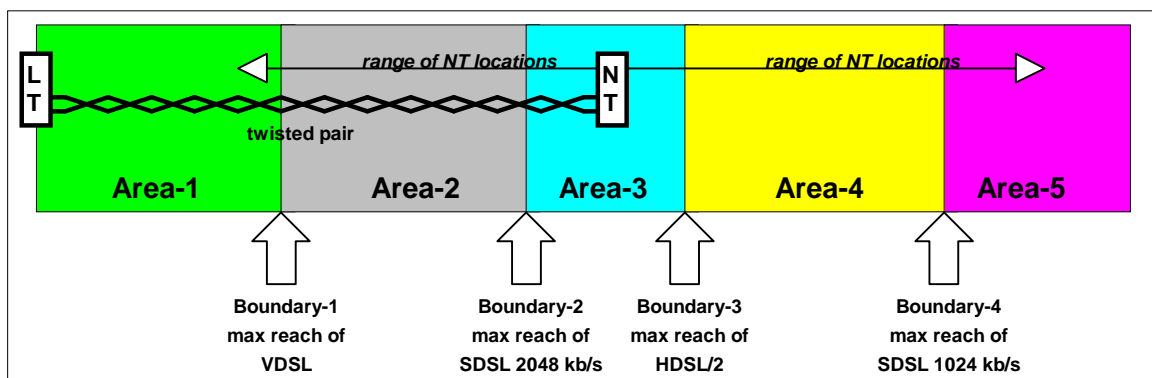

Figure 7: Concept of reach areas in ESP/2004, and associated boundaries

Boundary locations of the disturbers

The location of each boundary between two areas in figure 7 is scenario dependent, and is specified in table 49. Not all combinations of system mixtures and topology models are required for the ESP/2004 scenarios, and therefore table 49 is restricted to those combinations.

An example of the boundary values are summarized in table 49. These boundary values are assumed to be a fair reach estimation of the associated victim system, under the stress conditions of that particular scenario. Due to minor changes in the models, a reproduction of this table may not result in exactly the same numbers.

Table 49: Location of boundaries within the scenarios in ESP/2004

Area bounds	Boundary 1 (Area 1-2)	Boundary 2 (Area 2-3)	Boundary 3 (Area 3-4)	Boundary 4 (Area 4-5)
Scenario				
HP/M (distributed)	1 500 m	2 440 m	2 880 m	3 520 m
HP/R (co-located)	1 500 m	2 140 m	2 960 m	3 210 m
MP/P (co-located)	1 500 m	2 820 m	3 260m	4 050 m
MP/P (distributed)	1 500 m	2 820 m	3 270 m	4 200 m
MP/I (distributed)	1 500 m	2 890 m	3 380 m	4 300 m
MP/M (distributed)	1 500 m	2 840 m	3 280 m	4 020 m

NOTE: The estimations in table 49 have been carried out in a certain order, and all these systems operated with at least 6 dB of noise margin. First a system was considered that has the shortest reach in the given scenario. Next the system was considered that has the second shortest range in the same scenario, and so on. In addition, the following simplifications have been applied:

- Boundary 1 is fixed to 1 500 m. (*This is the right-hand boundary of area 1, representing the maximum deployment distance of VDSL.*)
- In scenarios where both HDSL.2B1Q/2 and HDSL.CAP/2 systems are present, boundary 3 represents the shortest reach of the two.

Handling disturbers in "distributed" topologies

Table 50 summarizes how to deal with the various disturbers in distributed topologies.

- Crosstalk from area 1 systems:** If a victim system is deployed beyond area 1, assume that VDSL is terminated at boundary 1 and disturbs the victim system by attenuated crosstalk.
- Crosstalk from area 2 systems:** If a victim system is deployed beyond area 2, assume that SDSL 2 048 kb/s is terminated at boundary 2 and disturbs the victim system by attenuated crosstalk.
- Crosstalk from area 3 systems:** If a victim system is deployed beyond area 3, assume that HDSL is terminated at boundary 3 and disturbs the victim system by attenuated crosstalk.
- Crosstalk from area 4 systems:** If a victim system is deployed beyond area 4, assume that SDSL 1 024 kb/s is regenerated and neglect the effect of the additional crosstalk by the repeaters somewhere between the LT and NT. However, the crosstalk that is generated by the SDSL 1 024 kb/s system at the end of the line should be taken into account.

Table 50: Summary of the disturbers to be considered in a distributed topology

Disturbers when victim NT is in				
Area 1	Area 2	Area 3	Area 4	Area 5
VDSL	X-1	X-1	X-1	X-1
SDSL-2048	SDSL-2048	X-2	X-2	X-2
HDSL	HDSL	HDSL	X-3	X-3
SDSL-1024	SDSL-1024	SDSL-1024	SDSL-1024	Reg. SDSL-1024
ADSL	ADSL	ADSL	ADSL	ADSL
ISDN	ISDN	ISDN	ISDN	ISDN
Reg-SDSL-1024 means regenerated SDSL 1 024 kb/2 systems X-n means attenuated crosstalk from area-"n"				

Handling disturbers in "virtually co-located" topologies

Table 51 summarizes how to deal with the various disturbers in virtually co-located topologies.

- Crosstalk from area 1 systems:** If a victim system is deployed beyond area 1, assume that a disturbing VDSL is terminated at boundary 1 and disturbs the victim system by attenuated crosstalk.

NOTE: The concept of "virtual co-location" conflicts with the concept of attenuated VDSL crosstalk up to area 5, but the impact of such crosstalk becomes ignorable beyond some distance.

- **Crosstalk from area 2 systems:** If a victim system is deployed beyond area 2, convert the disturbing SDSL 2 048 kb/s into an SDSL system with lower bitrate. For victims deployed in area 3 or 4, this bitrate equals 1 024 kb/s. For victims deployed in area 5, this bitrate equals 512 kb/s.
- **Crosstalk from area 3 systems:** If a victim system is deployed beyond area 3, assume that HDSL is regenerated and neglect the effect of the additional crosstalk by the repeaters in the middle of the line. However, the crosstalk that is generated by the HDSL system at the end of the line should be taken into account.
- **Crosstalk from area 4 systems:** If a victim system is deployed beyond area 4, assume that a disturbing SDSL 1 024 kb/s is regenerated and neglect the effect of the additional crosstalk by the repeaters in the middle of the line. However, the crosstalk that is generated by the SDSL 1 024 kb/s systems at the end of the line should be taken into account.

Table 51: Summary of the disturbers to be considered in a virtually co-located topology

Disturbers when victim NT is in				
Area 1	Area 2	Area 3	Area 4	Area 5
VDSL	X-1	X-1	X-1	X-1
SDSL-2048	SDSL-2048	SDSL-1024	SDSL-1024	SDSL-512
HDSL	HDSL	HDSL	Reg-HDSL	Reg-HDSL
SDSL-1024	SDSL-1024	SDSL-1024	SDSL-1024	SDSL-512
ADSL	ADSL	ADSL	ADSL	ADSL
ISDN	ISDN	ISDN	ISDN	ISDN

Reg-HDSL means regenerated-HDSL 2 pairs systems
SDSL-512 means a 512 kb/s SDSL system (or lower if that rate will not work either)
X-n means attenuated crosstalk from area-"n"

9.1.4 Loop models within ESP/2004

The models for transmission and crosstalk are specified in table 52. For the sake of simplicity, all effects related to the impedance for both the insertion loss and the crosstalk calculations are ignored. The impedance of 135 Ω is selected for all the systems, even if this is not correct for such systems like e.g. those belonging to the ADSL family.

Table 52: The involved models and associated parameters to account for various cable characteristics

Transmission	Two-port model	TP100	The TP100 cable model is described in annex A of the VDSL specification (TS 101 270-1 [10]). Bridge taps are assumed to be absent, and the characteristics of all cable sections in a cascade are assumed to be equal per unit length.
	Reference Impedance	$R_N = 135 \Omega$	The impact of the levels of signals, as a function of the termination impedance, is ignored for computational convenience. For calculating signal loss, assume that source and load impedance are $R_N = 135 \Omega$, for each xDSL system under study.
Crosstalk	Cumulation See clause 8.3.2		The FSAN sum for crosstalk cumulation, as specified in clause 8.3.2.1, applies for cumulating the power levels of M individual disturbers into the power level of an equivalent disturber.
	Coupling See clause 8.3.3	$K_{xn_dB} = -50 \text{ dB}$ $K_{xf_dB} = -45 \text{ dB}$ $f_0 = 1 \text{ MHz}$ $L_0 = 1 \text{ km}$	The basic models for equivalent NEXT and FEXT diagram for two-node topologies, as specified in clause 8.3.3.1, applies for modelling the equivalent crosstalk coupling.
	Injection See clause 8.3.4	$H_{xi} \equiv 1$	The impact on the levels of crosstalk noise, as a function of the termination impedance, is ignored for computational convenience (equivalent to $H_{xi} \equiv 1$).

9.1.5 Scenarios within ESP/2004

To carry out a spectral management study for a "new system" under ESP/2004, the six scenarios in table 53 are to be evaluated according to the reference method. This means that the change in performance is to be evaluated for each broadband system in the mix of each scenario, when the mix changes from the "reference mix" to the "modified mix" (as specified before in table 45).

Table 53: The combination of mixtures and topologies that form the scenarios of ESP/2004

Scenario	Mix	Topology
1	HP/M	distributed
2	HP/R	co-located
3	MP/P	co-located
4	MP/P	distributed
5	MP/I	distributed
6	MP/M	distributed

In addition, the following applies:

- All the systems shall have at least 6 dB of noise margin.
- The frequency resolution to be used in the simulations shall be 4,3125 kHz or smaller.
- A flat level of -140 dBm/Hz representative of background noise shall be added to the overall crosstalk noise.

Annex A: Bibliography

- ETSI-TM6(97)02: "Cable reference models for simulating metallic access networks", R.F.M. van den Brink, ETSI-TM6, Permanent document TM6(97)02, revision 3, Luleå, Sweden, June 1998 (970p02r3).

History

Document history		
V0.0.0	28 January 2002	Creation of TOC and first draft.
Rev 1	15 march 2002	Textual refinement of Scope, TOC and introductory text.
Rev 2	6 June 2002	Minor refinement on definitions.
Rev 3	6 Dec 2002	Insertion of models for receiver input block (+echo loss), a 2-node crosstalk model, and PSD templates for transmitter signal models HDSL.CAP/2 and SDSL.
Rev 4	28 may 2003	Insertion of generic detection models (Shifted Shannon; PAM, CAP/QAM). Correction of SDSL transmitter PSD. Rephrasing of few words and corrections of typo errors.
Rev 5	29 Aug 2003	Insertion of transmitter/disturber models for ISDN.2B1Q, and receiver performance models for HDSL.CAP and SDSL.
Rev 6	4 Feb 2004	Insertion of transmitter/disturber models for HDSL.2B1Q, and receiver performance models for the EC versions of "EC ADSL over POTS" and "EC ADSL over ISDN". Restructuring clause 5: Rephrasing the generic text of clause 5.1, by leaving out all details on out how to model echo. Move of the text of clause 7.2 to clause 5.3, because that was more appropriated, and a slightly rephrased for clarity. Removal of empty placeholders for all kinds of template PSDs for proprietary systems, since no contribution is received nor expected. These placeholders can be reinserted as soon as a proposal for the associated template PSDs is contributed to ETSI-TM6.
Rev 7	26 may 2004	Addition to the scope on the application of these computer models. Addition of definitions/terminology, identified in "part 3" to achieve consistent terminology among all 3 parts. Refinement of the associated text. Correction of typo in HDSL.CAP/2 template ($P=70$ dBm/Hz @ $f=297$ kHz). Insertion of PSD templates for four flavours of ADSL (EC and FDD, over POTS and over ISDN). Insertion of the generic DMT detection model.
Rev 8	6 July 2004	Insertion of text for power back-off for SDSL and ADSL transmitter models, and for the definitions. Insertion of receiver models for the FDD variants of ADSL, while leaving the values for min and maximum bit-loading explicitly for further study. Refinement of words in "definitions" and update of all "references" and "abbreviations". This version will be forwarded for AbC (Approval by Correspondence).
Rev 9	18 Nov 2004	Update of all editorial issues, collected during the AbC-procedure of august 2004, and agreed during the TM6 meeting of September 2004 (see contribution 043t32R1)

Rev 10	25 May 2005	Insertion of PSD templates for ISDN.MMS43, line shared ISDN.2B1Q, line shared ISDN.MMS43, ADSL2/J and ADSL2/M. Insertion of (provisionally agreed) solution for slope in downstream PSD template for ADSL (clearly marked as such).
Rev 11	8 June 2005	Finalizing slopes of ADSL template and out-of-band values of SDSL, insertion of transmitter models for filtered ISDN, HDSL.CAP/1 and VDSL, insertion of receiver models for FDD variants of ADSL and HDSL.2B1Q. Insertion of references to cable models. Insertion of ESP/2004.
Rev 12	17 June 2005	Editorial update of text fragments, and editorial reshuffle of sections in clause 8 on crosstalk. Replacing values in table 49 (boundary locations of ESP/2004) by values in 034t32, and extrapolating for boundary 2 of "MP/T" scenario since 023t32 evaluated it for SDSL.2304 instead of SDSL.2048.
Rev 13	12 July 2005	Fixed spelling error in "Line rate" column of table 40 to 43
Rev 14	September 2005	Pre-processed by the ETSI Secretariat <i>editHelp!</i> E-mail: mailto:edithelp@etsi.org
Rev 15	22 Sept 2005	Editorial update of what has been agreed during the ETSI-TM6 meeting of September, and what has been received afterwards during AbC The document is now officially approved by ETSI!